

USER'S MANUAL

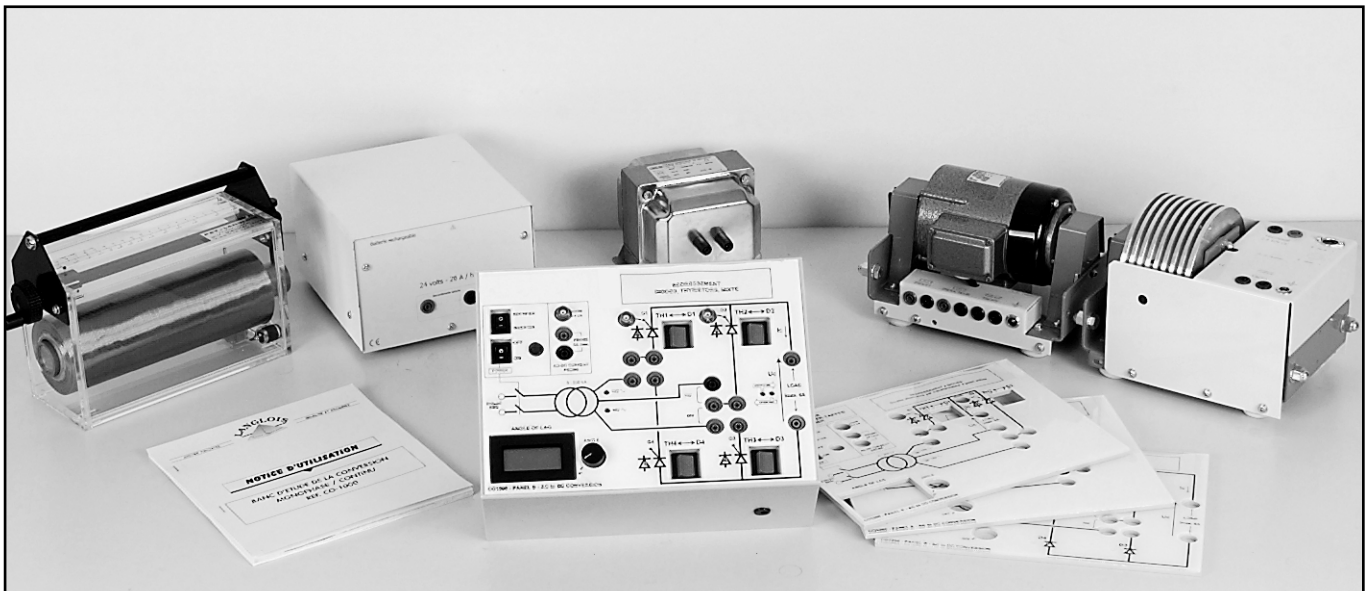

SINGLE-PHASE / DIRECT CURRENT CONVERSION TEST BENCH REF. CO-1000

SINGLEPHASE AC-to-DC CONVERSION BENCH

CO-1000

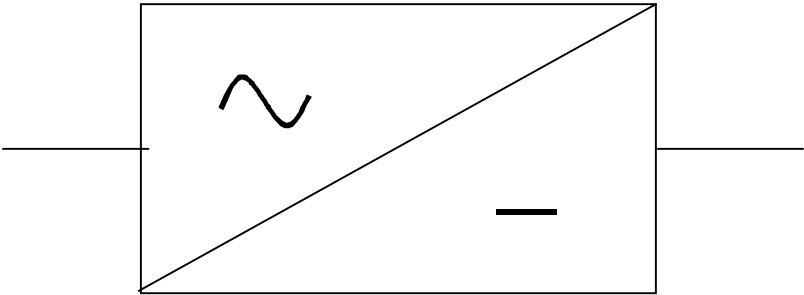

TABLE OF CONTENTS

<u>PREAMBLE</u>	3
<u>INTRODUCTION</u>	4
<u>SETTINGS</u>	5
<u>TECHNICAL SPECIFICATIONS</u>	6
I SECURITY, ENVIRONMENT AND EMC.....	6
II ELECTRICAL CHARACTERISTICS.....	7
III INSTRUCTIONS OF USE AND SECURITY.....	11
IV FUSES AND POWER COMPONENTS REPLACEMENT.....	12
<u>FEATURES</u>	14
I LOCATION OF CONTROLS.....	14
II MEASURE AND VIZUALIZATION OF CURRENTS.....	17
III REMOVABLE FRONT PANELS. UNCONTROLLED RECTIFICATION.....	19
IV REMOVABLE FRONT PANELS. CONTROLLED RECTIFICATION.....	22
<u>PRACTICAL WORKS : UNCONTROLLED RECTIFICATION</u>	25
I PRELIMINARY SURVEY ON DIODES ASSOCIATION.....	25
II HALF WAVE AND FULL WAVE CENTER TAPPED RECTIFICATION.....	29
PANEL A – EXP N°1 : RESISTIVE LOAD.....	32
PANEL A – EXP N°2 : INDUCTIVE LOAD.....	37
III BRIDGE RECTIFIER DIODE.....	39
PANEL B – EXP N°1 : RESISTIVE LOAD.....	40
PANEL B – EXP N°2 : INDUCTIVE LOAD – SMOOTHING INDUCTANCE.....	42
PANEL B – EXP N°3 : ACTIVE LOAD.....	44
PANEL B – EXP N°4 : ACTIVE INDUCTANCE LOAD.....	48
PANEL B – EXP N°5 : DC MOTOR.....	50
<u>PRACTICAL WORKS : CONTROLLED RECTIFICATION</u>	52
I HALF WAVE AND FULL WAVE CENTER TAPPED RECTIFICATION.....	53
PANEL C : RESISTIVE LOAD.....	55
II FULL SCRs BRIDGE RECTIFIER.....	58
PANEL D – EXP N°1 : ACTIVE LOAD.....	59
PANEL D – EXP N°2 : DC MOTOR.....	65
III SCRs/DIODES BRIDGE RECTIFIER.....	66
PANEL D – EXP N°3 : ACTIVE INDUCTANCE LOAD.....	67
PANEL D – EXP N°4 : DC MOTOR.....	72

PREAMBLE

- With the development of switching components and digital processing, electrotechnics is taking a major place in industrial activities as in electrical engineering, power distribution, transports improvement...
- Nowadays, power and control electronics appear to have many applications fields and provide for electrotechnics many ambitious prospects.
- Teachers from technical and professional departments, where practical work must be a priority, are naturally ready to motivate pupils and students to follow electrotechnics studies.
- The present bench deals with ac-to-dc conversion.

INTRODUCTION

- An ac-to-dc converter supplies dc voltage or dc current to a load from an ac source.

An ac-to-dc converter is symbolically pictured as :

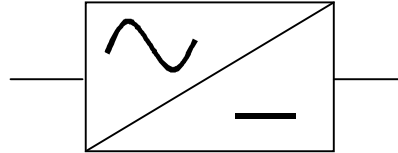

- Electromechanic converters have been replaced by power electronics where switching systems, based on semiconductor components, are more and more efficient.

Those systems present many advantages as :

- low dimensions
- low cost
- maintenance free
- silent
- high efficiency
- high flexibility at use

SETTINGS

- This bench presents several originalities so much convenient than educational.
- It contains all devices required for single phase ac-to-dc conversion, such as rectifiers (diodes) and SCRs and can be used for high school practical works.
- The bench is used with four removable panels on which clearly appears the following conversion chain:

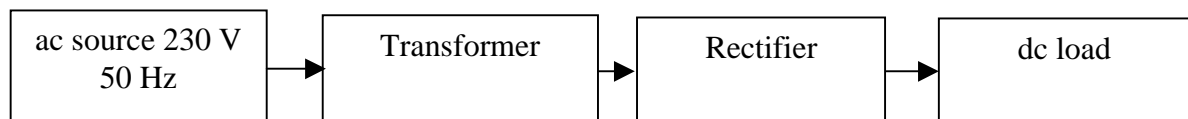

- This bench constitutes a convenient help for the teacher during demonstration lectures and its utilization is strongly recommended for pupils who chose to follow a practical teaching.
- Rectifier circuits can be chosen by means of four removable panels suited to specific application :
 - Panel A : Full wave center-tapped rectifier
 - Panel B : Bridge rectifier diode
 - Panel C : SCRs full wave center-tapped rectifier
 - Panel D : Bridge rectifier (SCRs or SCRs/diodes)

A single bench with its four panels allows to study all kind of ac-to-dc conversions (singlephase) and with the same case, the teacher will choose the corresponding panel to each practical work.

An immediate comparison between controlled and uncontrolled components is available by means of switch which commutes a SCR into a diode. This may introduce motor speed-variation.

For active inductance load, *rectifier* or *wave generator* mode is displayed by two indicators.

- Rectifier mode : the load is supplied by mains
- Wave-generator mode : the load (added to a generator) supplies mains

TECHNICAL SPECIFICATIONS

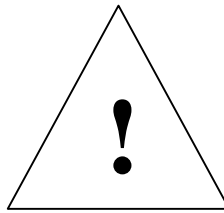

I SECURITY, ENVIRONMENT AND EMC

A Security

This bench uses secured connections however it is recommended to use a high differential circuit-breaker (30 mA).

The socket power unit must be grounded (CLASS 1 case)

Primary and secondary windings (power supply transformer) are respectively protected by two fast fuses (4 A and 6.3 A).

Electronic stage is protected by a 500 mA fuse

Warning

Refer servicing to qualified personnel only

B Environment

Use: +10 °C to 40°C

Storage: 0°C to 50°C

C EMC

This bench complies with European EMC rules;

Mains interference, output terminals interferences, radiated interferences, mains harmonic

II ELECTRICAL CHARACTERISTICS

This device complies with secured voltages :

Less than 50 V rms (ac)

Less than 120 V (dc)

A Power supply

Transformer : apparent power $S = 200 \text{ VA}$

1) Full wave center-tapped rectifier power supply

Power supply : $2 \times 15 \text{ V rms}$

$$V_1(t) = 15\sqrt{2} \sin \omega t$$

$$V_2(t) = 15\sqrt{2} \sin \omega t$$

2) Bridge circuit power supply

According to dc load

one winding only

$$V_1(t) = 15\sqrt{2} \sin \omega t$$

full winding

$$V_2(t) = 30\sqrt{2} \sin \omega t$$

B Power rectifier components

The bench is a « closed-box ». In order to avoid overheating it is recommended to oversize rectifiers (diodes) and SCRs.

1) Rectifier (diode)

- We must consider :

Maximal average forward current I_{FAV} or I_o
Maximum peak repetitive forward current I_{FM} or I_{FRM}
Repetitive peak inverse voltage V_{RRM}

- We will impose $I_{FAV} \gg 3A$ and $V_{RRM} \gg 50V$ and the rectifier package must fit with location (194 plastic type).
- A fast rectifier can be used and speed characteristics must be taken in account :

Reverse recovery time t_{rr}
Maximum reverse current I_R or I_{RM}

Example :

POWER RECTIFIER		194 Plastic Package
	I_{FAV}	6A
V_{RRM}	200	MR 752
	400	MR 754
	600	MR 756

2) SCR

SCR owns the same characteristics as a rectifier but we must be add :

Holding current I_H
Latching current I_L
Gate trigger current I_{GT}
Gate trigger voltage V_{GT}
Current slew rate (conducting state) di/dt
Voltage slew rate (blocking state) dv/dt
Turn off time t_q

SCRs are protected against overvoltage by means of RC circuit.

We must also consider :

- Rms on-state current I_{TRMS}
- Average forward current I_{TAV}
- Repetitive peak off-state voltage V_{DRM} or V_{RRM}
- Peak on-state voltage V_{TM}

As for rectifiers, fast SCRs can be used looking at package type (TO 220)

Example :

POWER SCR		PLASTIC PACKAGE TO 220 AB	
I_{TRMS}		8A	12A
V_{DRM}	200	MCR 72-4	2N 6396 TIC 126 B
	400	MCR 72-6	2N 6397 TIC 126 D

C Load

Whatever the load, the maximum current I_{max} must equal 6A either with half bridge or full bridge arrangements.

We can use the following loads :

- **Load resistor**

Rheostat ref. ECO ½ TUBE (320 W)
 (10 Ω ; 5.7 A) ; (15Ω ; 4.5 A) (22 Ω ; 3.8 A) (33 Ω ; 3.1 A) for best use, low resistance load must be adopted.

- **Inductance loads**

Variable inductance 0.1 H to 1.4 H/10Ω/2A ref. PSYJR
 Smoothing inductance 20 mH/3A ref. CO-105
 Dismantle transformer coils (with or without iron core)
 Winding :125 ; 250 ; 500 ; 1000.

- **Active load**

Accumulator cell (lead) ref. CO-106
 6V ; 12V ; 24V

- **DC motor** ref. SH 90/24

Armature supply 24V/6.4 A
Inductor supply 24V/0.62 A
Speed detector 200Hz-5VAC-1000 rpm

Magnetic brake ref. FR 90
Braking voltage 0-10 V (DC)
Current 0-60 mA

The previous devices are just given as examples and other kind of loads could be used provided that electrical characteristics of the bench are respected.

D Current probe, LEM

LEM probe is based on Hall effect. It is made of a primary stage (high current) plugged within the circuit (CURRENT PROBE) and the secondary stage is plugged to a scope (BNC socket). Galvanic insulation is made between both stages.

This probe can measure ac, dc and TRMS currents.

The maximum current must be 6A and the probe sensitivity is 0.5V/A.

E Angle of lag ; control and display

1) Trigger

Triggering is synchronized with mains and a pulse transformer provides a galvanic insulation.

2) Angle of lag

This tuning is realized by means of a potentiometer.

Two different modes are available :

- Rectifier mode : $0 \leq \alpha \leq 180^\circ$
- Wave generator mode : $100^\circ \leq \alpha \leq 170^\circ$

The beginning of conduction is obtained with rectifier (diode) for $\alpha = 0^\circ$.

3) Angle of lag ; external control

The angle of lag can be controlled by an external dc voltage :

$$0 \leq V_{\text{ext}} \leq 12\text{V} \quad \text{for} \quad 0 \leq \alpha \leq 180^\circ$$

4) Angle of lag display

Its measure can be obtained either from the LCD display of the bench or from a scope screen.

5) Pulse chains

Two channels

First channel : 20 kHz pulse chains applied to G1 and G2, range [α ; 180°]

Second channel : 20 kHz pulse chains applied to G3 and G4, range [$180^\circ + \alpha$; 360°]

III INSTRUCTIONS OF USE AND SECURITY

The user should scrupulously respect for his own security and the one of the bench the main following recommendations:

- 1) Look after the different devices such as seers, emergency stops, meters, scope...at the beginning and at the end of each practical work session.
- 2) Work out an operative method before every manipulation.
- 3) The yellow and green coloured earth terminal of the module must be connected by means of earth wire (same colour) to the power supply desk and to the loads that are endowed with.
- 4) Use secured \varnothing 4 mm wires only.
- 5) To avoid electrical shock, any intervention must be done after disconnecting the ac power cord.
- 6) Once the circuit is checked by the teacher, this latter will switch on the desk power supply.
- 7) Do not overpass the maximum ratings of power components and loads.
- 8) In order to measure and visualise current, do not plug nor disconnect cords of the buckle if current has not been cut-off.

WARNING: The bench is a class 1 device, the metallic part of the current probe is grounded.

The utilisation of a differential probe is necessary if the measure of the current is not referenced to the mass of the installation.

One can use $0.1\Omega / 5 \text{ W}$ or $1 \Omega / 40 \text{ W}$ shunts while being careful to connect the mass correctly to one of their terminals.

9) In order to measure and to visualise any tension, connect scope and voltmeter at last. Think about the utilisation of a differential probe if any mass problem is encountered.

10) Use carefully accumulators cell (beware of short circuit).

IV FUSES AND POWER COMPONENTS REPLACEMENT

No particular maintenance is required for this bench. However install it in a dry place and avoid any inclined position.

WARNING : Unplug the module from the power source before replacing any fuse or damaged component (beware of active loads).

A Fuses replacement

WARNING : Any fuse replacement must be done with a fuse which presents the same characteristics (type, size,)

1) Power stage

Fuses are placed on the rear panel in fuse holders.

- Primary winding (mains) :

One $4 \text{ A} / 250 \text{ Vpp} / 5 \times 20 \text{ mm}$ fast fuse

- Secondary winding :

Two $6.3 \text{ A} / 250 \text{ Vpp} / 5 \times 20 \text{ mm}$ fast fuses

2) Electronic stage

Electronic stage is protected by fuse holder soldered on printed-circuit.

- Primary winding (mains) :

One 500 mA / 250 Vpp /5 * 20 mm temporized fuse

B Power components replacement

WARNING : If one or some components are damaged, it is recommended to check the others devices even if they seem undamaged.

Power components can be unscrewed from the protective panel (transparent cover).

1) SCR replacement

After finding the SCR location, unscrew the damaged SCR, place the new one (place a tested SCR). Verify the SCR terminals are well screwed before a new experiment.

2) Rectifier replacement

Adjust its terminals.

Unscrew the damaged rectifier, place the new one (the central screw is not used, use a tested diode).

Before using, verify that the tension is 15 V rms across both windings transformer (while connection straps are removed and no load is connected).

Warning: Check the load is not shorted.

FEATURES

LOCATION OF CONTROLS

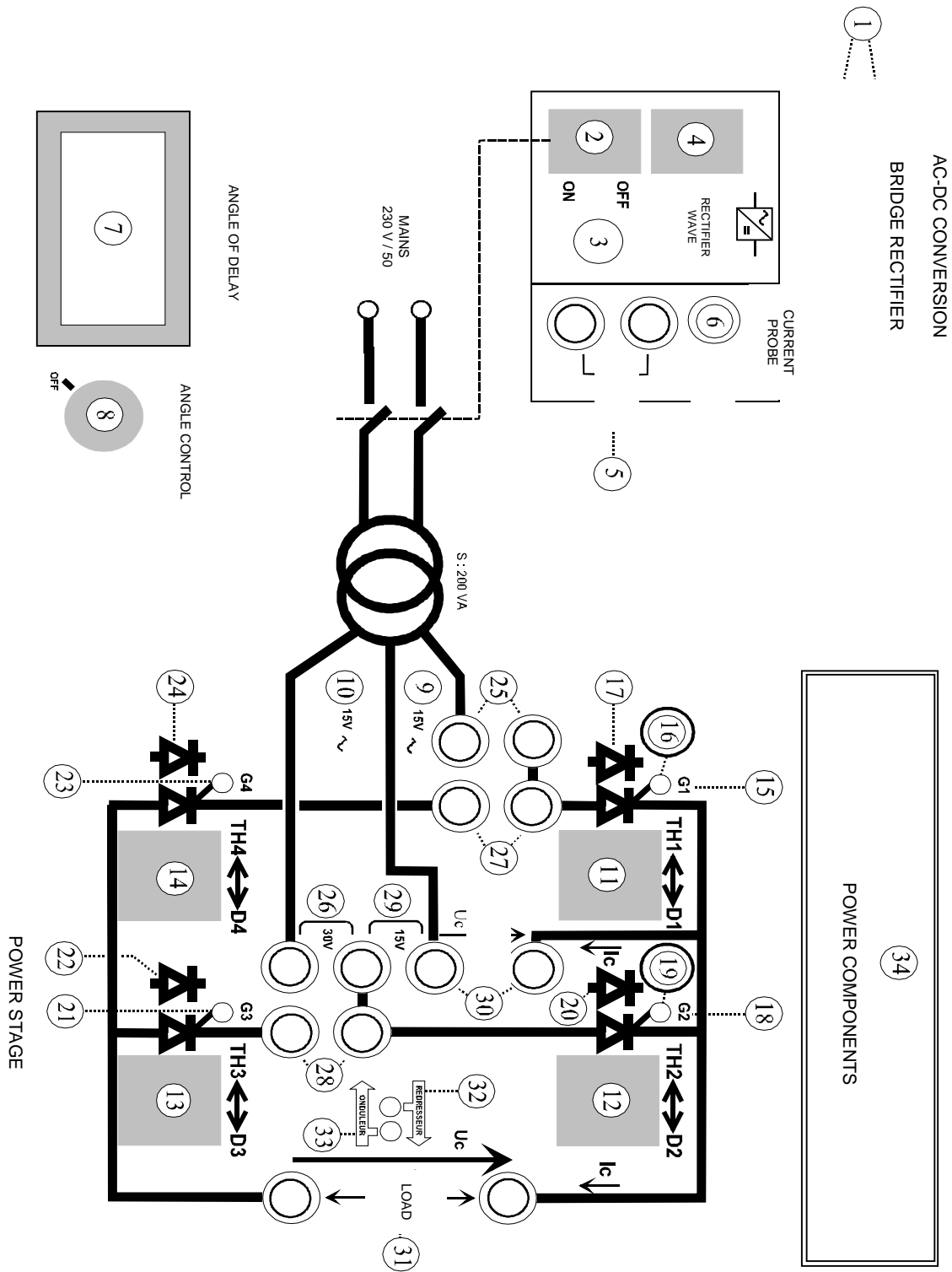

- (1) Title of the circuit
- (2) Power switch
- (3) Power supply indicator
- (4) Rectifier or Wave generator selector (for controlled rectifiers only)
- (5) Current probe terminals. $I_{max} = 6 \text{ A}$
- (6) Coaxial output for the current probe(to scope), 0.5 V/A
- (7) Angle of lag display while control (8) is turned on.
- (8) Angle of lag control

Rectifier mode : $0^\circ \leq \alpha \leq 180^\circ$

Wave generator mode : $100^\circ \leq \alpha \leq 170^\circ$

- (9) First half winding of the source transformer indicator (orange).
- (10) Second half winding of the source transformer indicator (orange)
- (11) Rectifier or SCR selector :

Left position ; T_{h1} on , D_1 off
 right position ; T_{h1} off, D_1 on
- (12) Rectifier or SCR selector :

Left position ; T_{h2} on , D_2 off
 Right position ; T_{h2} off, D_2 on
- (13) Rectifier or SCR selector :

Left position ; T_{h3} on , D_3 off
 Right position ; T_{h3} off, D_3 on
- (14) Rectifier or SCR selector :

Left position ; T_{h4} on , D_4 off
 Right position ; T_{h4} off, D_4 on
- (15) T_{h1} indicator (red) when (11) is on left position
- (16) BNC socket output for G_1 gate signal (same as G_3) of T_{h1} . 20 kHz , $[\alpha ; \pi^\circ]$ range pulses chain.
- (17) D_1 indicator (green) when (11) is on right position

- (18) T_{h2} indicator (red) when (12) is on left position
- (19) BNC socket output for G_2 gate signal (same as G_3) of T_{h2} . 20 kHz, $[\pi + \alpha ; 2\pi^\circ]$ range pulses chain
- (20) D_2 indicator (green) when (12) is on right position
- (21) T_3 indicator (red) when (13) is on left position
- (22) D_3 indicator (green) when (13) is on right position
- (23) T_4 indicator (red) when (14) is on left position
- (24) D_4 indicator (green) when (14) is on right position
- (25) Connection strap ; $V_1(t)$ to circuit
- (26) Connection strap ; $V_2(t)$ to circuit
- (27) Connection strap ; link between rectifier devices (1) and (4). First half of the bridge circuit.
- (28) Connection strap ; link between rectifier devices (2) and (3). Second half of the bridge circuit.
- (29) Connection strap ; 15 V power supply
- (30) Load connections, *full wave center-tapped rectifier* mode
- (31) Load connections, *bridge rectifier* mode
- (32) Rectifier indicator (green), *bridge rectifier* mode
- (33) Wave generator indicator (red), *bridge rectifier* mode
- (34) Power components (Rectifiers, SCRs)

First row : (T_{h1} , T_{h2} , T_{h3} , T_{h4}) Second row : (D_1 , D_2 , D_3 , D_4)

II MEASURE AND VISUALIZATION OF CURRENTS

Every currents can be visualized or measured by means of the different connection straps positions :

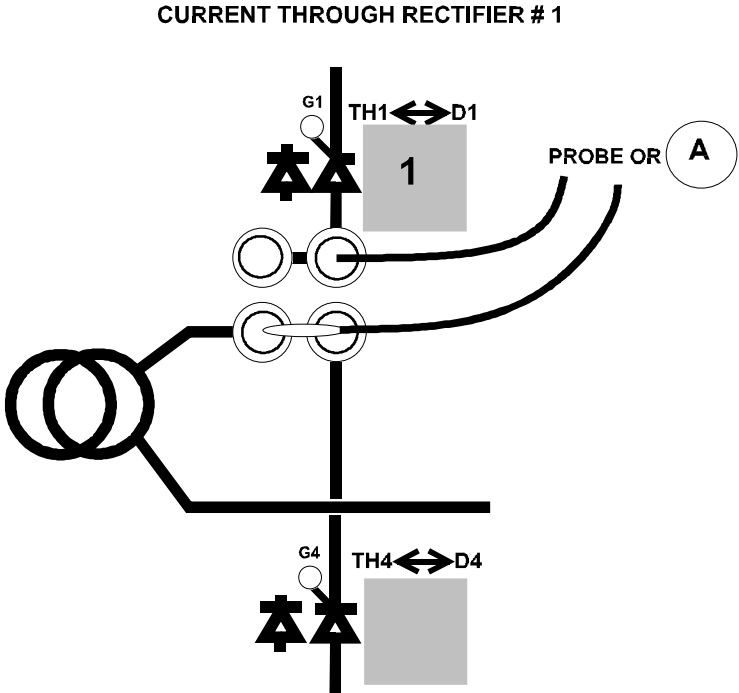
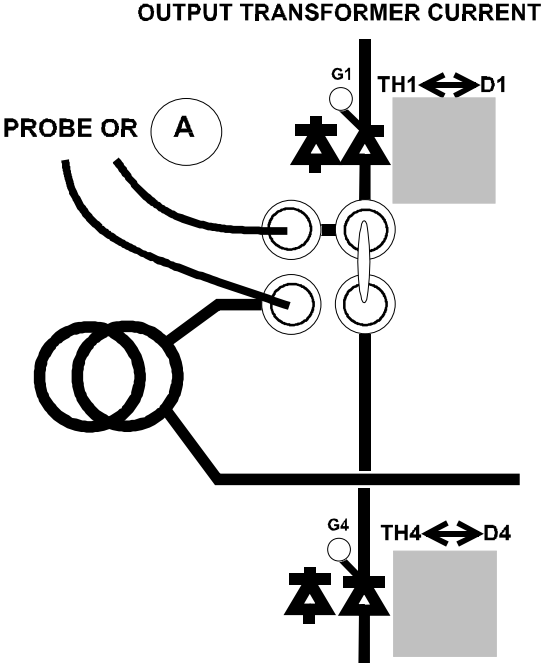

CURRENT THROUGH RECTIFIER # 4

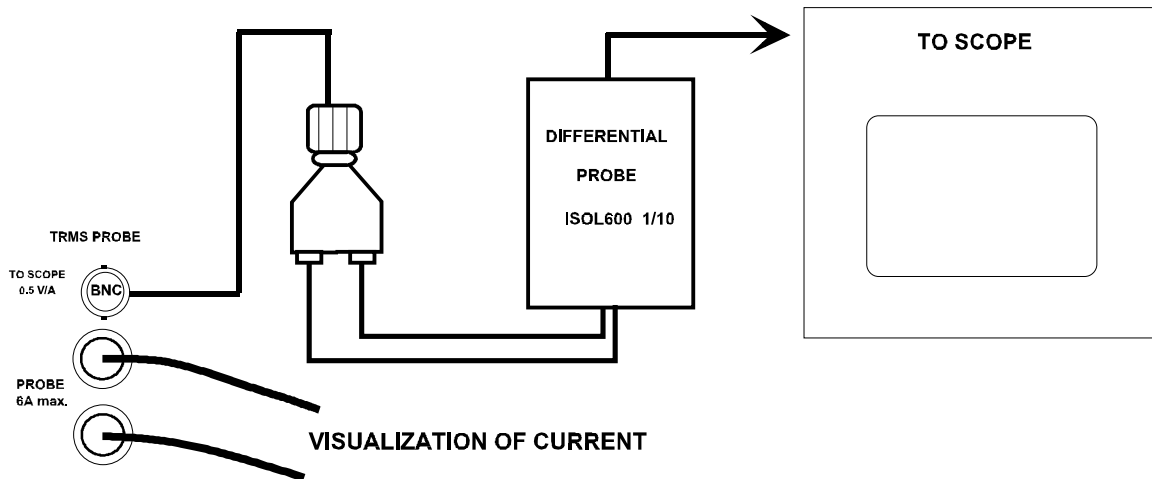
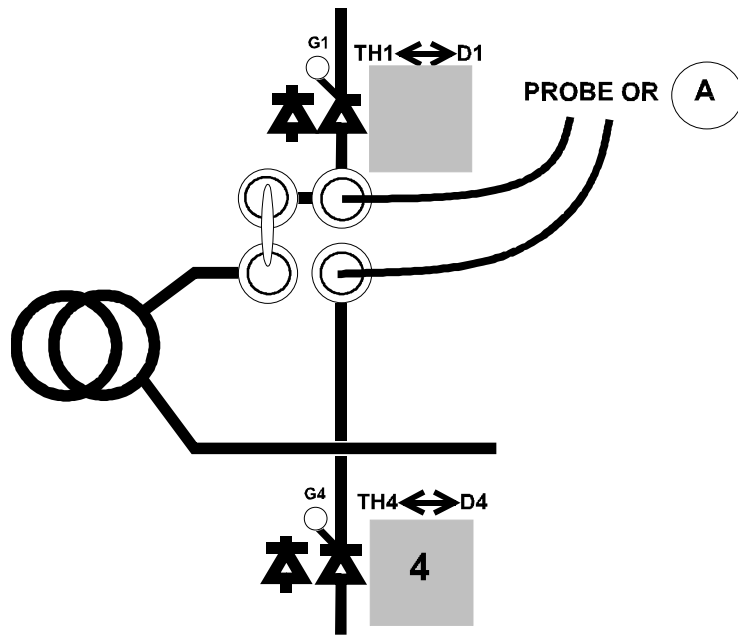

III REMOVABLE FRONT PANELS. UNCONTROLLED RECTIFICATION

PANEL A :

**FULL WAVE CENTER-TAPPED RECTIFIER
(TWO DIODES)**

PANEL B :

BRIDGE RECTIFIER DIODE

**SINGLE PHASE AC-DC CONVERSION
UNCONTROLLED RECTIFICATION**

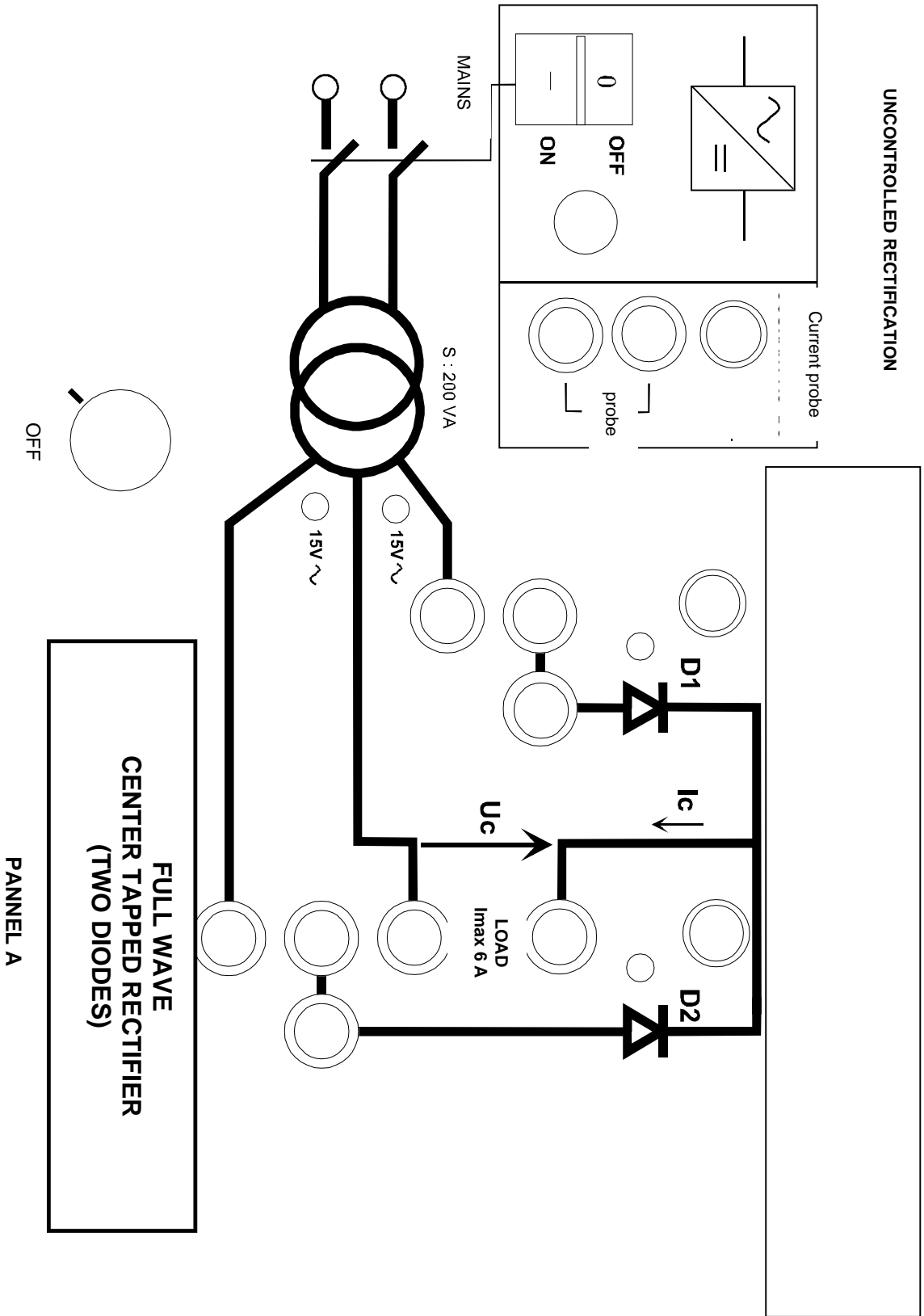

SINGLE PHASE AC-DC CONVERSION
BRIDGE RECTIFIER DIODE

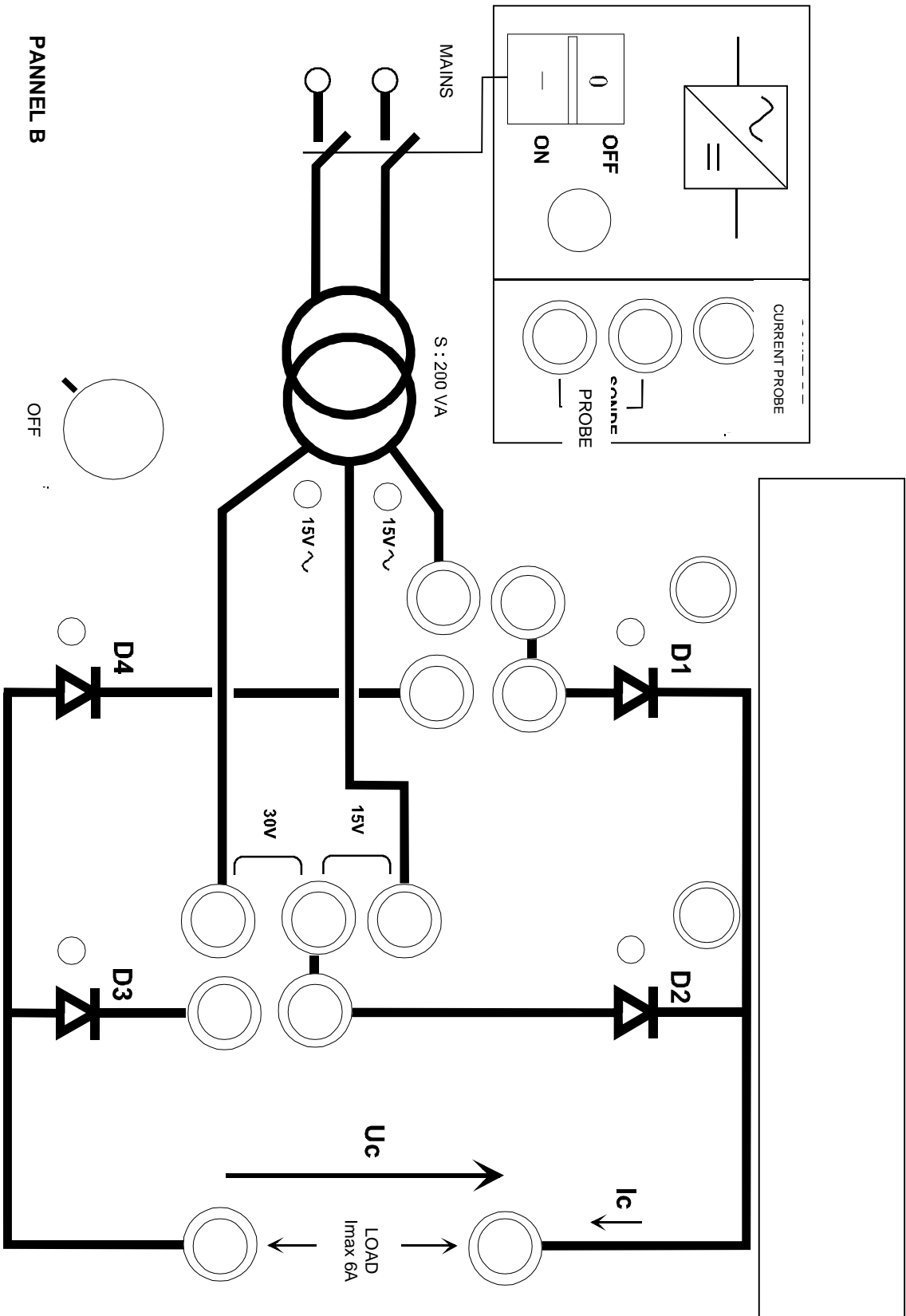

IV REMOVABLE FRONT PANELS. CONTROLLED RECTIFICATION

PANEL C :

**SCRs CENTER-TAPPED RECTIFIER
(TWO SCRs)**

PANEL D :

BRIDGE RECTIFIER (FULL SCRs OR SCRs AND DIODES)

SINGLE PHASE AC-DC CONVERSION

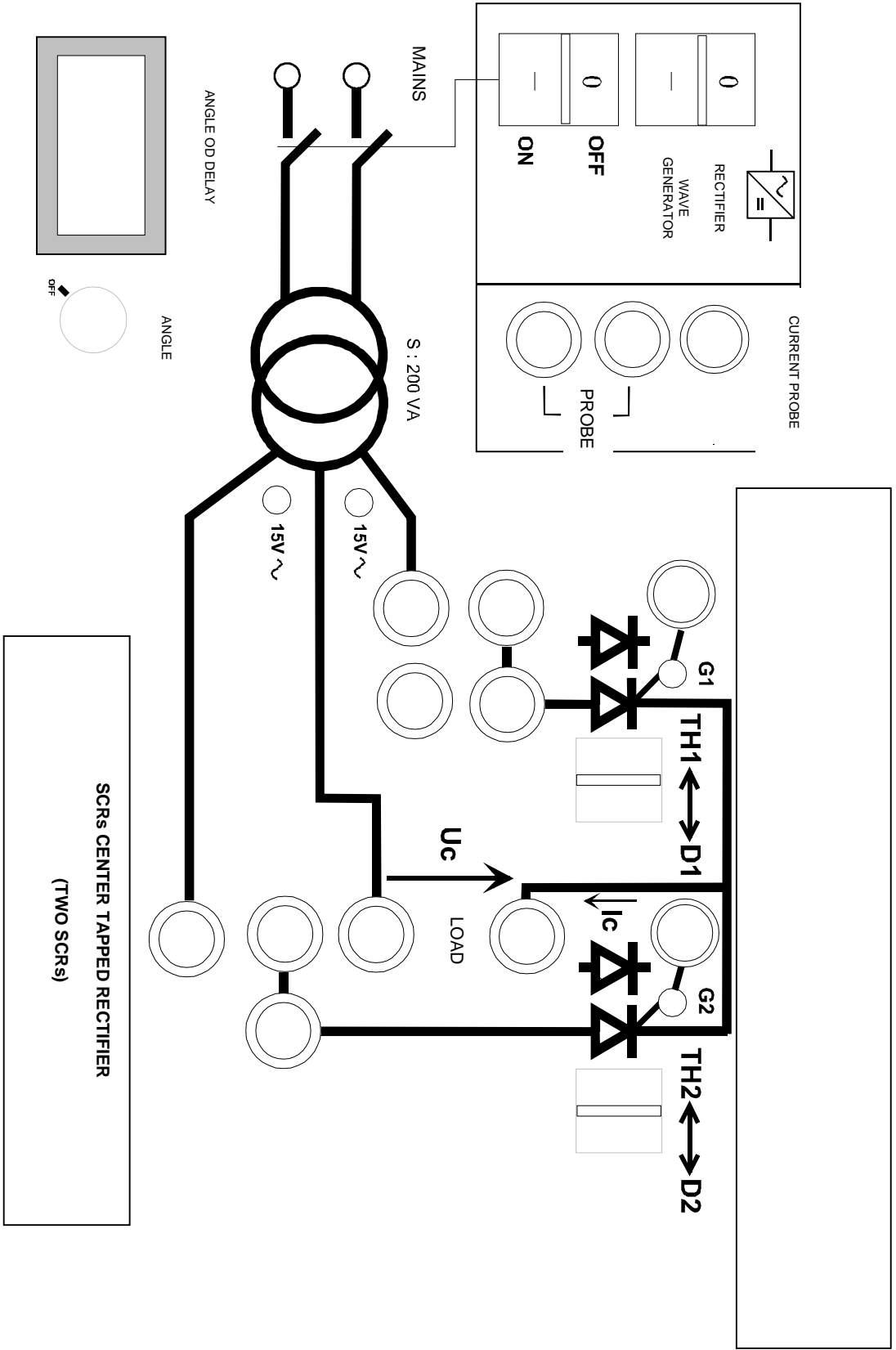

SINGLE PHASE AC-DC CONVERSION

BRIDGE RECTIFIER

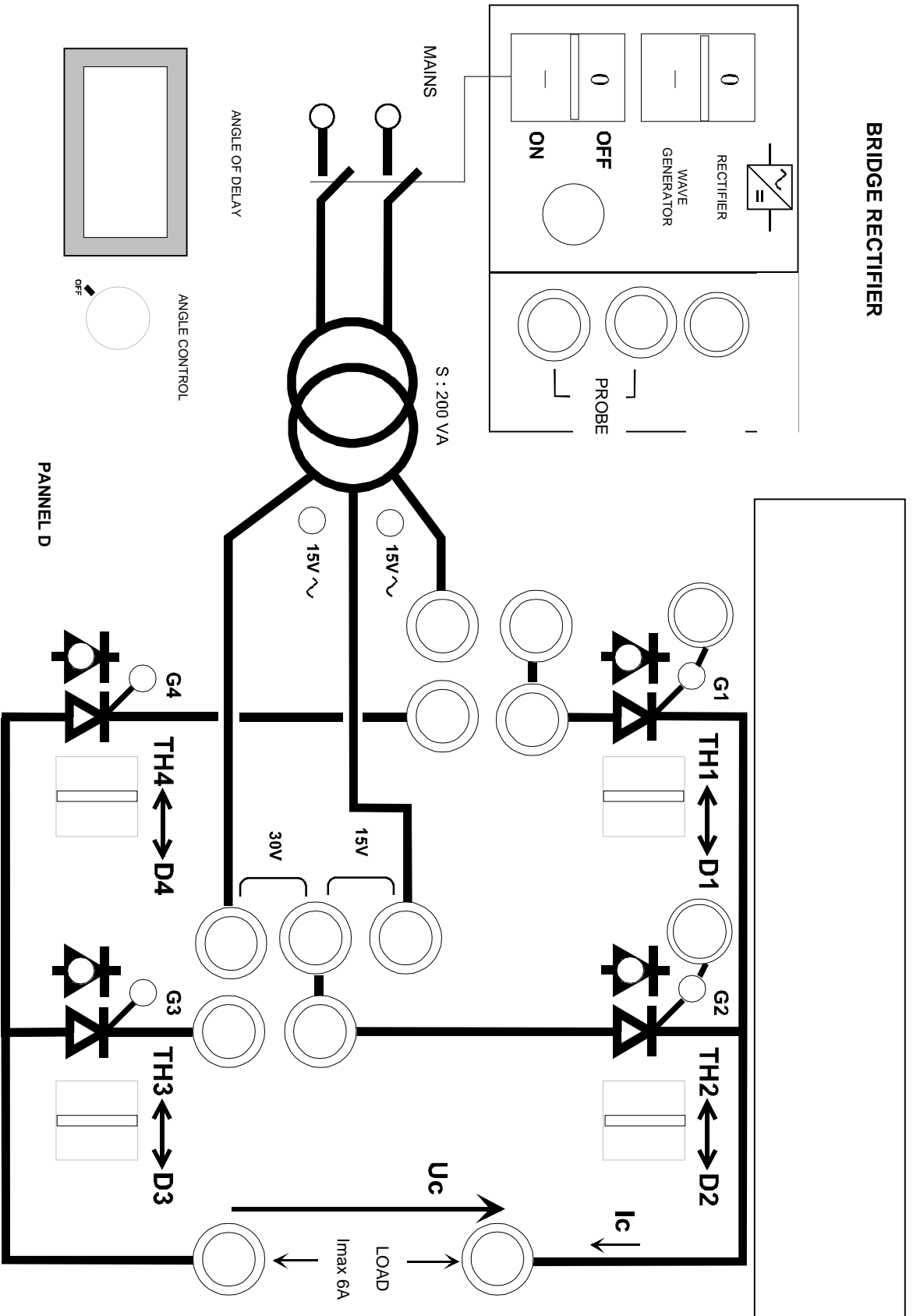

PRACTICAL WORKS : UNCONTROLLED RECTIFICATION

I PRELIMINARY SURVEY ON DIODES ASSOCIATION

The aim of this survey is to introduce uncontrolled components as diodes (rectifiers).

The following applications need dc power supply.

A Cathode biasing

DL₁ : green LED

DL₂ : red LED

V_{A1}, V_{A2} : DC power supply (0 – 30 V)

R : 1 kΩ / ¼ W resistance

➤ Circuit :

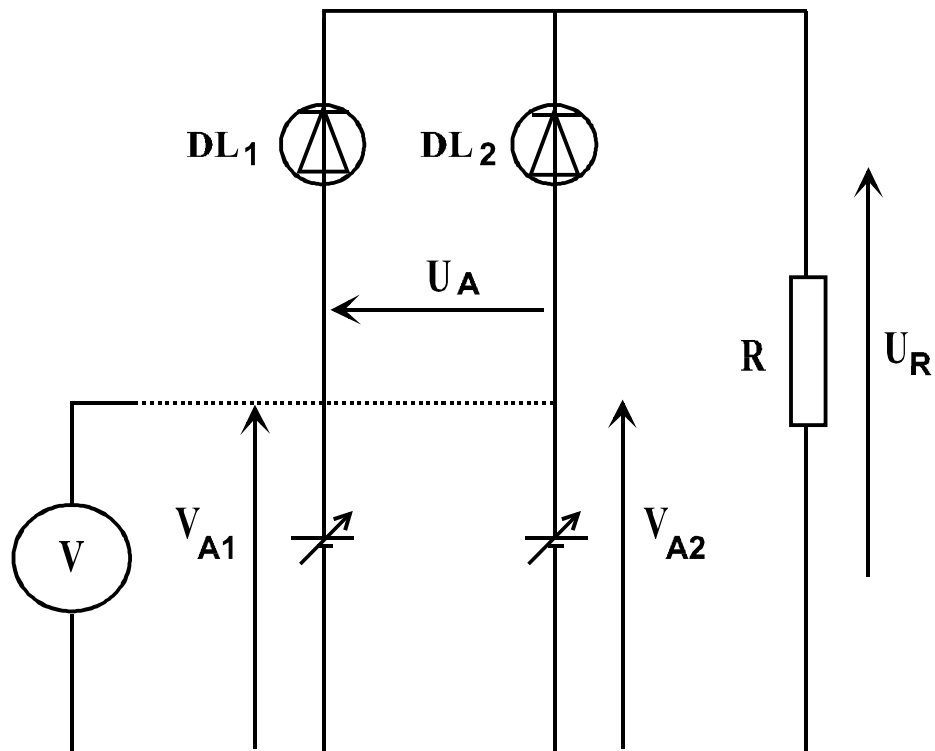

Let's fill the following table :

	V_{A1}	V_{A2}	U_A	DL_1	DL_2	U_R
$V_{A1} > V_{A2}$	+15 V	+10 V				
$V_{A1} < V_{A2}$	+10 V	+15 V				

First result: When cathodes of these 2 diodes are biased each other, the conducting diode is the one whose anode's potential is superior to the anode's potential of the other diode.

This result will be generalized (specially with three-phase rectifier circuits) by comparison of anode's potential.

If $V_{DL1} \ll V_{A1}$ and $V_{DL2} \ll V_{A2}$ then a diode can be considered as a switch (ideal component) and its threshold voltage will be neglected.

Therefore we can picture a diode as an one-way switch :

Conduction state (closed switch): $V_D = 0$ V
 Blocking state(open switch): $i_D = 0$ A

This hypothesis will be justified when we use the bench.

Second result: For a common cathodes association we notice that the conducting diode forces its anode's potential to the cathode of the other diode.

This result could be generalized to.

These results will be seen again with center-tapped circuit.

B Anodes biasing

DL3 : green LED

DL4 : red LED

V_{K3}, V_{K4} : DC power supply (0 – 30 V)

R : 1 k Ω / ¼ W resistor

➤ Circuit :

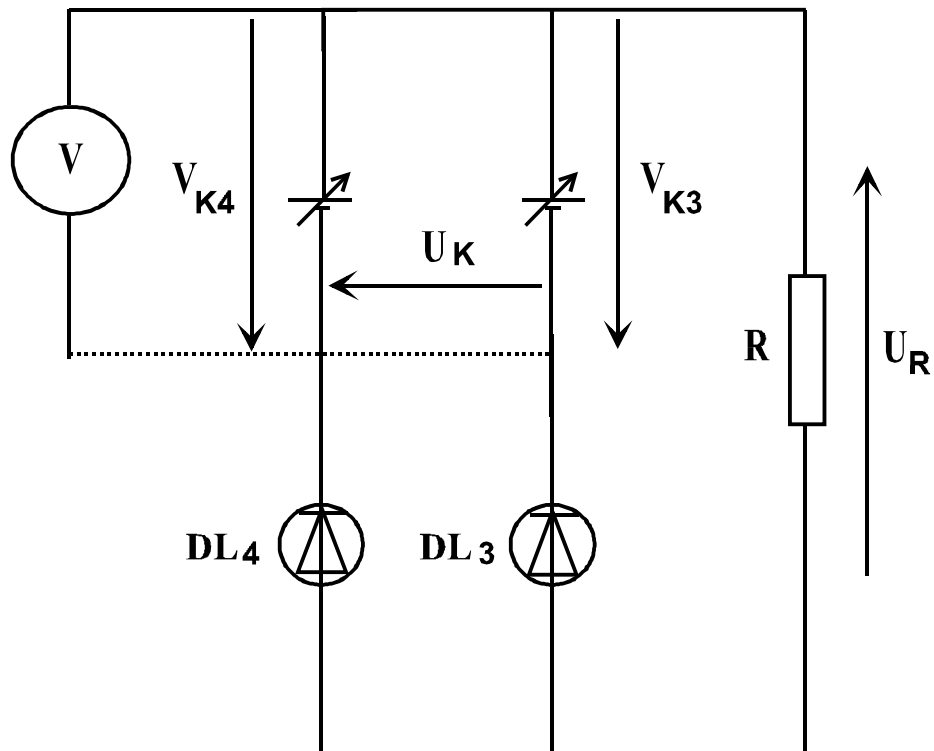

Let's fill the following table :

	V_{K3}	V_{K4}	U_K	DL_3	DL_4	U_R
$V_{K3} < V_{K4}$	-15 V	-10 V				
$V_{K3} > V_{K4}$	-10 V	-15 V				

First result: When anodes of these 2 diodes are biased each other, the conducting diode is the one whose cathode's potential is inferior to the cathode's potential of the other diode.

Second result: For a common anodes association we notice that the conducting diode forces its cathode's potential to the anode of the other diode.

As the previous survey, these results can be generalized.

C Bridge rectifier diode

DL₁ : green LED DL₃ : green LED

DL₂ : red LED DL₄ : red LED

U : DC variable power supply (0 – 30 V)

R : 1 kΩ / ¼ W resistance

Circuit :

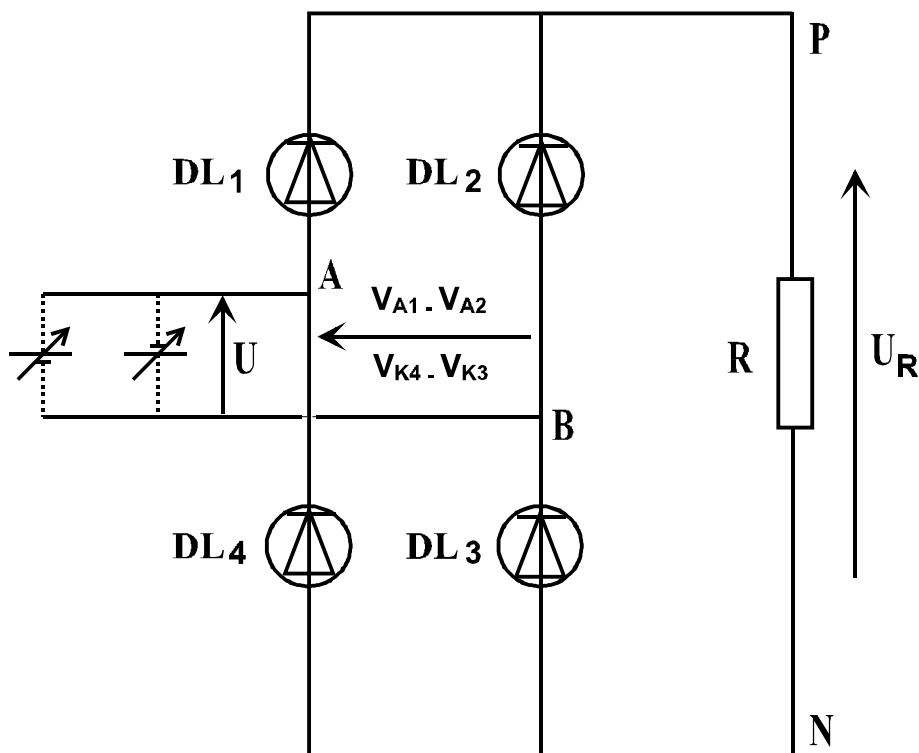

➤ $U > 0$ and $U < 0$

- note the state of diodes
- measure the potential in A then in B with respect to P or N.
- explain the behavior of the circuit after the two previously filled tables.
- justify the fact that:

The conduction of a diode involves the other to be in blocking state

Remarks: These results suppose that a load is connected. Diodes, transformer are supposed idealized and encroachment is ignored. This confirms the representation of diodes by ideal switches.

II HALF WAVE AND FULL WAVE CENTER TAPPED RECTIFICATION

Both applications remind the operative mode of diode in power electronics and underline the fact that it behaves in ac-to-dc conversion as a commutating switch.

Half wave survey is available by means of center-tapped circuit. The load is placed between the middle point of the transformer winding (M) and both cathodes (S) of D_1 and D_2 .

Each transformer winding is connected by connection straps to the anode of each diode.

We can use only one connection strap in order to realized a half wave rectifier see **fig1.a.** and **fig1.b.**

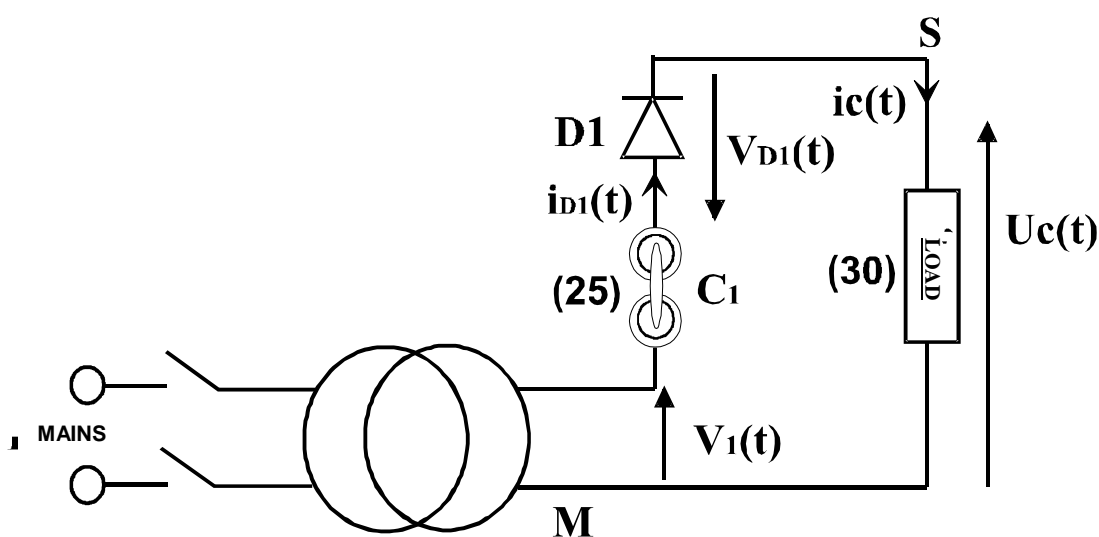

Fig.1.a

➤ Half wave rectification

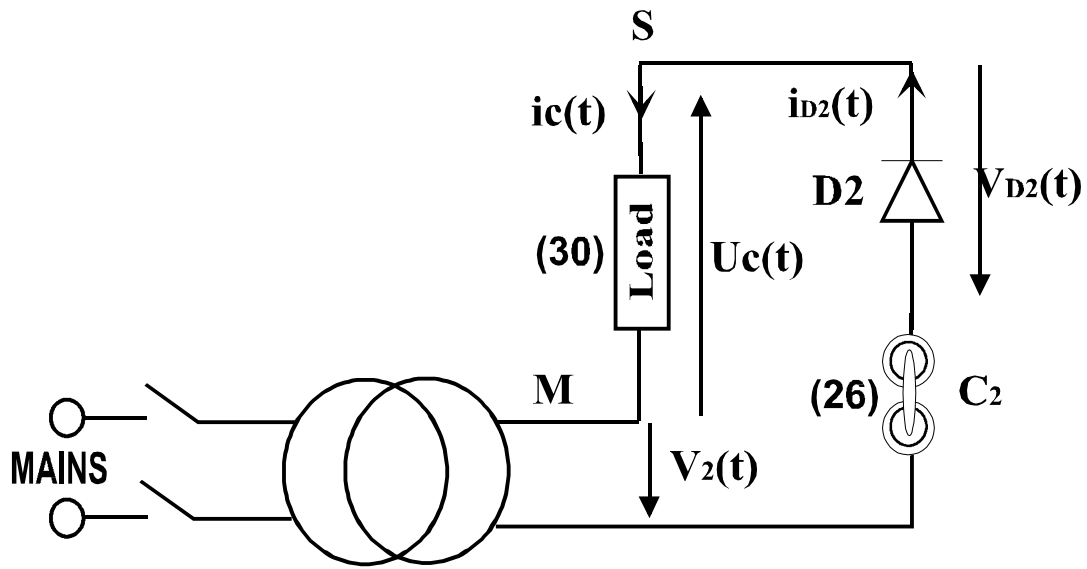

Fig1.b

Full wave rectification is obtained when two connection straps are used simultaneously, see fig1.c.

➤ Full wave rectification

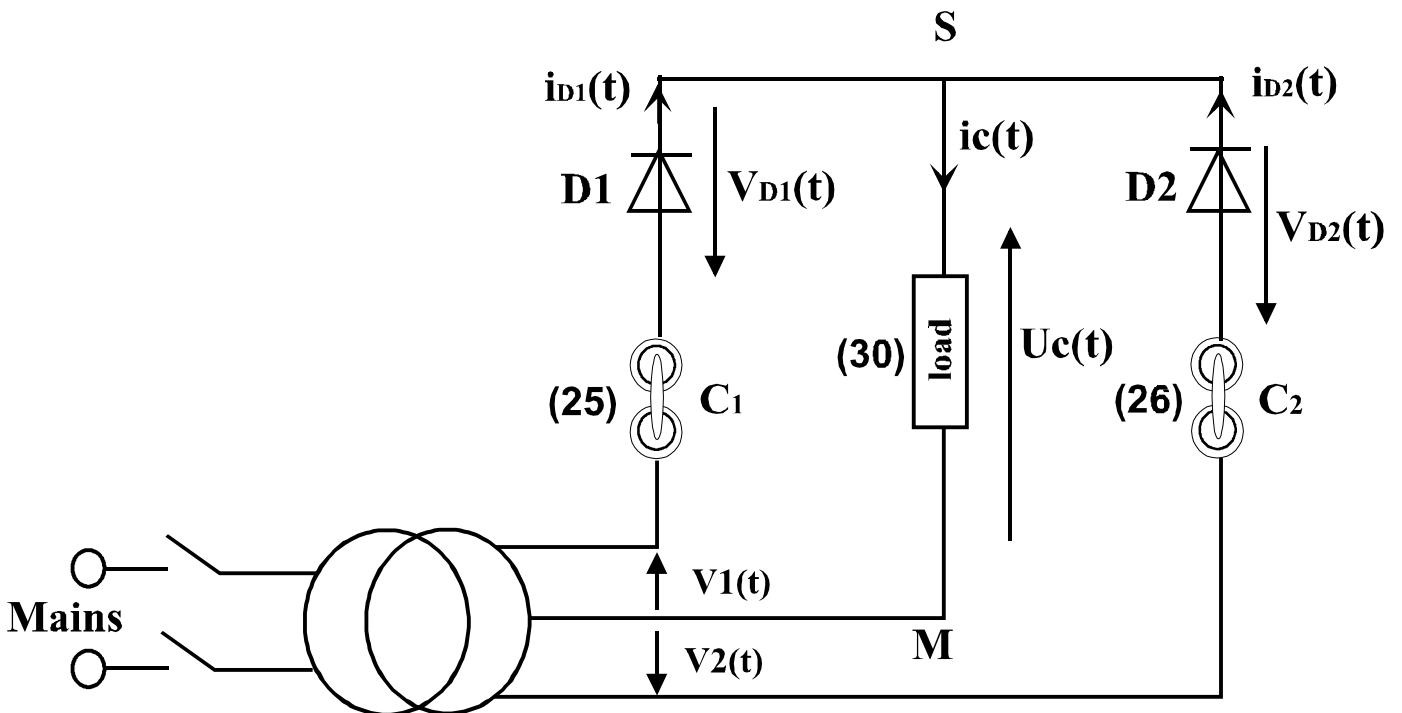

Fig1.c

It would be better to use an analog scope with the following characteristics :

- memory function
- vertical sensibility : 10V / div – 20V / div
- « INV » mode for both channels

Source triggering and chopped mode are suitable

A digital scope makes the visualization of 50 kHz signals much easier than an analog scope. Moreover it allows mathematics operations as average, sum, Fourier transform...and cursors may be suitable to check conduction interval times.

PANEL A EXP N°1 : RESISTIVE LOAD

A Circuit diagram

LOAD : 10 Ω /5.7 A (320 W) or 15 Ω /4.5 A (320 W) Rheostat, R_h

➤ **Half wave and full wave rectification**

Two arrangements are used :

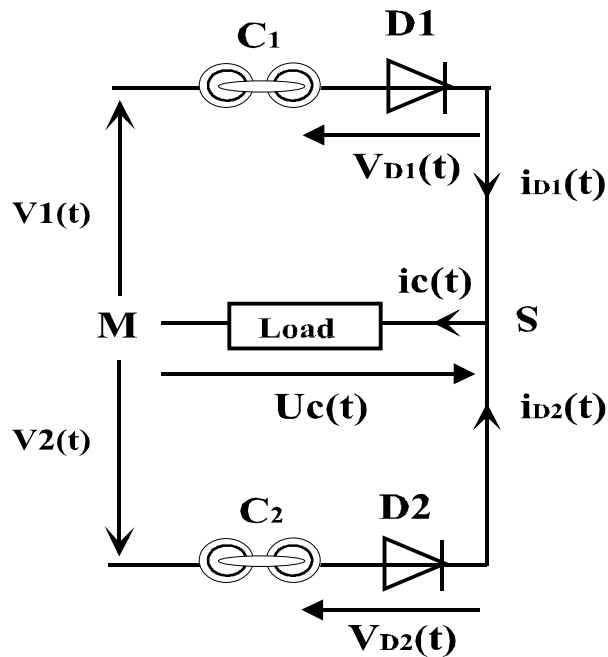
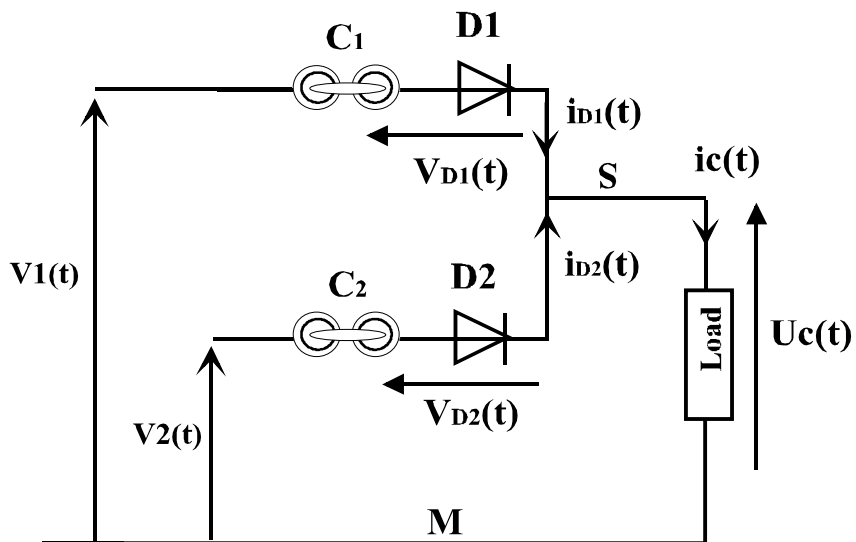

- **No connection straps**

B Tensions waveforms

➤ **Half wave rectification**

1 Visualize $V_1(t)$ on channel 1 (ground potential is M point)

Explain why the tops of the sine wave are flat

Give the maximum value \hat{V}_1 of $V_1(t)$

- **Place the load between S and M points. Use C_1 connection strap only.**

2 Keep $V_1(t)$ on channel 1 and visualize $U_C(t)$ on channel 2.

Give the maximum value \hat{U}_C of $U_C(t)$.

3 Keep these settings and use « INV » and « ADD » functions in order to visualize $V_{D1}(t)$.

Give the maximum value \hat{V} of $V_{D1}(t)$.

- **Remove C_1 place C_2**

4 Visualize $V_2(t)$ on channel 1 and $U_C(t)$ on channel 2

Give the maximum value V_2 of $V_2(t)$

Compare $V_1(t)$ to $V_2(t)$ and V_1 with \hat{V}_2

5. Keep these settings, and repeat 3 in order to visualize $V_{D2}(t)$.

Give the maximum value \hat{V}_{D2} of $V_{D2}(t)$

➤ **Full wave rectification**

▪ **Both connection straps**

1 Sketch $U_C(t)$ and measure its frequency.

2 Visualize $U_C(t)$ after removing and placing again successively C_1 and C_2 .

3 Both straps are placed, sketch $V_{D1}(t)$, $V_{D2}(t)$ below $U_C(t)$ and give their maximum values.

C Currents wave forms

➤ **Single wave rectification**

▪ **C_1 only**

1 Visualize and picture $i_{D1}(t)$ and $i_C(t)$ below $V_1(t)$ graph.

▪ **C_2 only**

2 Visualize and picture $i_{D2}(t)$ and $i_C(t)$ below $V_2(t)$ graph.

➤ **Full wave rectification**

▪ **Both straps are placed**

1 What about $i_{D1}(t)$ and $i_{D2}(t)$?

2 Sketch $i_C(t)$ below $V_1(t)$, $V_2(t)$ and $U_C(t)$.

D Operating analysis

➤ Half wave rectification

After voltages waveforms explain the action of the circuit.

1 Show that the diode behaves as a switch and verify the following expressions :

$$V_1(t) = U_C(t) + V_{D1}(t) \quad (C_1 \text{ only})$$

$$V_2(t) = U_C(t) + V_{D2}(t) \quad (C_2 \text{ only})$$

2 Give a conclusion about diodes threshold voltage and the secondary winding of the transformer (supposed ideal).

Remark : State under each waveform the name of the conducting diode.

3 After the waveforms of currents, justify the behavior of each diode

4 Compare the current passing through the load and the one passing through the diode.

➤ Full Wave rectification

After voltages waveforms explain the action of the circuit.

1 Describe briefly half wave rectification compared to full wave rectification and deal with $U_C(t)$.

2 Compare diodes maximum inverse voltage (value and shape)

3 Explain why superposition method is not available in these conditions.

4 After currents waveforms, justify the state of each diode and verify the following expression :

$$i_C(t) = i_{D1}(t) + i_{D2}(t)$$

5 Show that $i_C(t)$ is a one-way current ; from S to M.

6 After waveforms give a conclusion about this converter.

E Remarkable values

1 Compare your results with the following table :

LOAD	\hat{U}_c	$\frac{U_c}{AC + DC}$	\bar{U}_c DC	\hat{I}_c	I_c	\bar{I}_c
HALF WAVE RECTIFICATION	\hat{V}	$\frac{\hat{V}}{2}$	$\frac{\hat{V}}{\pi}$	$\frac{\hat{V}}{Rh}$	$\frac{\hat{I}_c}{2}$	$\frac{\hat{I}_c}{\pi}$
FULL WAVE RECTIFICATION	\hat{V}	$\frac{\hat{V}}{\sqrt{2}}$	$\frac{2\hat{V}}{\pi}$	$\frac{\hat{V}}{Rh}$	$\frac{\hat{I}_c}{\sqrt{2}}$	$\frac{2\hat{I}_c}{\pi}$

How to measure the ac part U_{CA} of $U_C(t)$?

What about U_C and \bar{U}_c ?

2 Fill the following table

DIODE	\hat{U}_{Drev}	\hat{I}_D	I_D	\bar{I}_D
HALF WAVE RECTIFICATION				
FULL WAVE RECTIFICATION				

PANEL A EXP N°2 INDUCTANCE LOAD

A Circuit

LOAD: 10 Ω /5.7 A (320 W) or 15 Ω /4.5 A (320 W) rheostat, Rh and coil with its iron core

➤ **Half wave rectification**

▪ **C₁ and C₂ are placed**

- We use a 0.1 H to 1.4 H variable inductance, with an internal resistor $r = 10 \Omega$

1 Picture the circuit.

2 From the previous survey (resistive load), what changes are encountered towards $i_{D1}(t)$, $i_{D2}(t)$ and $i_C(t)$?

Justify the expression « continuous conduction ».

What about the inductance towards the shape of $U_C(t)$?

3 If $L = L_1 = 0.1 \text{ H}$; $L = L_2 = 0.5 \text{ H}$; $L = L_3 = 1.2 \text{ H}$ sketch $U_C(t)$ and $i_C(t)$.

Verify $U_C(t) = U_{rh}(t) + U_L(t)$ when $L = 1.2 \text{ H}$.

Why $\bar{U}_L \neq 0$?

Give the theoretical expression of \bar{U}_c

4 Note that \bar{I}_c remains unchanged whatever L value (DC mode).

Measure this value and compare it with its theoretical expression :

$$\bar{I}_c = \frac{2\hat{V}}{\pi R_T}$$

Where $R_T = r + R_h$

5 A free wheeling diode D_f is placed in parallel with the load. Show that D_f has no action.

6 The current wave ratio is given by τ .

$$\tau = \frac{I_{ca}}{\bar{I}_c}$$

Where I_{ca} is the rms part of $i_c(t)$.

How does τ behave compare to L ?

Give a conclusion about the function of the inductance

Make a comparison between L/R_T and $T/2$ for L ranging from 0.1 H to 1.4 H.

Plot $\tau = f(L)$.

Confirm these results if we consider :
$$I_{ca} = \frac{4}{3\pi} \frac{\hat{V}}{\sqrt{R_T^2 + (2L\omega)^2}} .$$

(first harmonic approximation)

Work out τ without L .

Compare τ values respectively to L values and show that $\tau \approx \frac{1}{3\sqrt{2}} \frac{R_T}{L\omega}$. when $R_T \ll 2L\omega$

➤ **Half wave rectification**

▪ **Remove C_2**

- **We chose $L = L_1 = 0.13$ H**

1 Visualize and deal about conduction conditions. Sketch $U_C(t)$ and $i_C(t)$.

Explain why $U_C(t)$ is not a half wave tension.

Explain $i_C(t)$ waveform

2 Place in parallel with the load a free wheeling diode D_r .

Explain why $U_C(t)$ is a half wave tension.

Explain $i_C(t)$ wave form, what happens while L is increasing ?

Deal with the free wheeling diode.

III BRIDGE RECTIFIER DIODE.

Full wave rectification is reached with center-tapped transformer. Very used for symmetric dc power supply, it is not very suitable for high-voltage applications. In this second case, a bridge rectifier diode is used.

The transformer is not a center-tapped on and it is smaller than the previous one. On the inverse cycle, each diode has only transformer voltage across its terminals.

Bridge rectifier circuit :

(11), (12), (13) and (14) are in right position (diode mode)

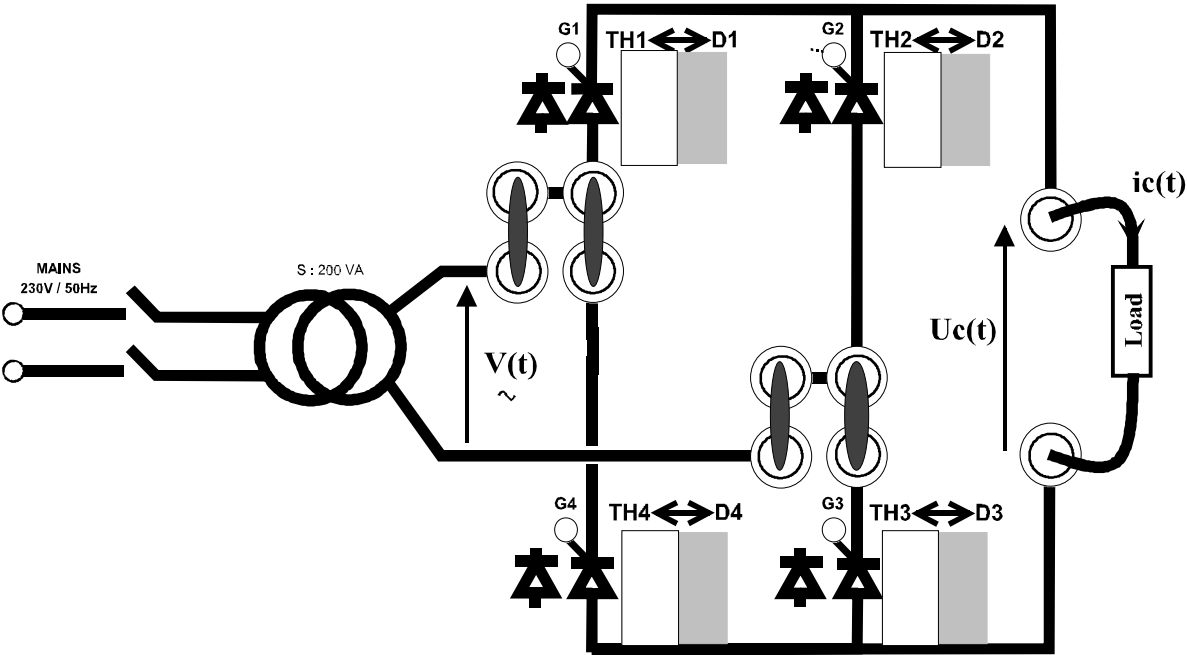

PANEL B EXP N°1 RESISTIVE LOAD

LOAD : 10 Ω / 5.7 A (320 W) or 15 Ω / 4.5 A (320 W) Rheostat, Rh

1 Picture the circuit.

2 Sketch $V(t)$ and $U_C(t)$

How to visualize simultaneously both signals ?

3 Sketch $V_{D1}(t)$, $V_{D2}(t)$, $V_{D3}(t)$ and $V_{D4}(t)$ voltage across each diode.

Sketch $i_{D1}(t)$, $i_{D2}(t)$, $i_{D3}(t)$ and $i_{D4}(t)$ current in each diode.

Sketch the transformer output current $i_s(t)$ and the load current $i_c(t)$.

4 Explain the action of the circuit (the diode is idealised).

Verify instantaneous relations of voltage and current.

State the name of conducting diodes.

5 Measure \bar{U}_c and \bar{I}_c and verify Ohm's law across the load.

6 We notice wave phenomenon with \bar{U}_c and \bar{I}_c .

let's introduce : τ = wave ratio
 F = shape factor

Fill the following table :

	\bar{U}_c DC	U_{Ca} AC	U_C AC+DC	$\tau = \frac{U_{Ca}}{\bar{U}_c}$	$F = \frac{1}{\tau}$
Practical results					
Theoretical results	$\frac{\hat{V}}{\pi}$	$\sqrt{U_c^2 - \bar{U}_c^2}$	$\frac{\hat{V}}{\sqrt{2}}$	0.48	1.11

\bar{U}_c is average value of $U_C(t)$

U_{Ca} is the rms value of the ac part of $U_C(t)$

U_c is the rms value of $U_C(t)$

Deal with these results

What about τ and F ?

We would measure the rms value V of $V(t)$ with a magnetoelectric meter (dc mode only).

Show that across the load, $\bar{U}_c \approx V$

7 Which passive component could enhance this wave phenomenon ?

PANEL B EXP N°2 INDUCTANCE LOAD- SMOOTHING INDUCTANCE

In power electronics, currents are often waving and that may trouble loads.

Losses may appear with dc-motors for example. Therefore we place a high value inductance, called smoothing inductance, in series with the load. That make the current to become rather constant.

This experiment deals with the function of a smoothing inductance in series with a resistive load R_h .

LOAD : Resistor R_h and a variable inductance L (ref. PSYJR)

1 Draw the circuit. We chose $L = 1.2$ H

2 Visualize and sketch $V(t)$ and $U_C(t)$.

Sketch $V_{D1}(t)$, $V_{D2}(t)$, $V_{D3}(t)$ and $V_{D4}(t)$ voltage across each diode.

Sketch $i_{D1}(t)$, $i_{D2}(t)$, $i_{D3}(t)$ and $i_{D4}(t)$ current in each diode.

Sketch the transformer output current $i_S(t)$ and the load current $i_C(t)$.

Explain the function of the inductance and specify the condition of conduction.

Compare these signal shapes with the previous experiment (resistive load).

What about the inductance and the shape of $U_C(t)$?

Verify the following expression : $U_C(t) = U_{rh}(t) + U_L(t)$

3 Compare \hat{U}_c with \hat{V}

Measure \bar{U}_c and compare with its theoretical value : $\frac{2\hat{V}}{\pi}$

Measure \bar{I}_c and verify this value from the relationship between \bar{U}_c and R_T ($R_T = r + R_h$)

4. Power:

As diodes are idealized no losses appear between the secondary of the transformer and the load.

We assume that : $P_S = P_{load} = \bar{U}_c \bar{I}_c$

Measure P_S and P_{load} with a wattmeter (upstream and downstream arrangements).

We assume that $S = V I_S$ even if I_S is not a sine wave.

Show that $I_S = \bar{I}_c$ and write S as a function of \hat{V} and \bar{I}_c

Calculate the power factor $k = \frac{P}{S}$

Compare k with 0.9 (theoretical value).

Deal with its high value. Find this result with a phasemethod.

6 Disrupting conduction

Replace the previous inductance by a dismantle transformer coil with and without iron core :

$L_1 = 125$ windings

$L_2 = 250$

$L_3 = 500$

$L_4 = 1000$

Deal with $U_C(t)$ and $I_C(t)$.

Deal with every waveforms and notice how conduction times are changed.

PANEL B EXP N°3 ACTIVE LOAD

Battery behaves as dc load and can be considered as an ideal dc voltage generator in series with a resistor.

Such load does not need any smoothing inductance.

A circuit

LOAD : 10 Ω /5.7 A (320 W) or 15 Ω /4.5 A (320 W) Rheostat, Rh (ref. ECO ½) and a 6V or 12 V battery (ref. CO-106)

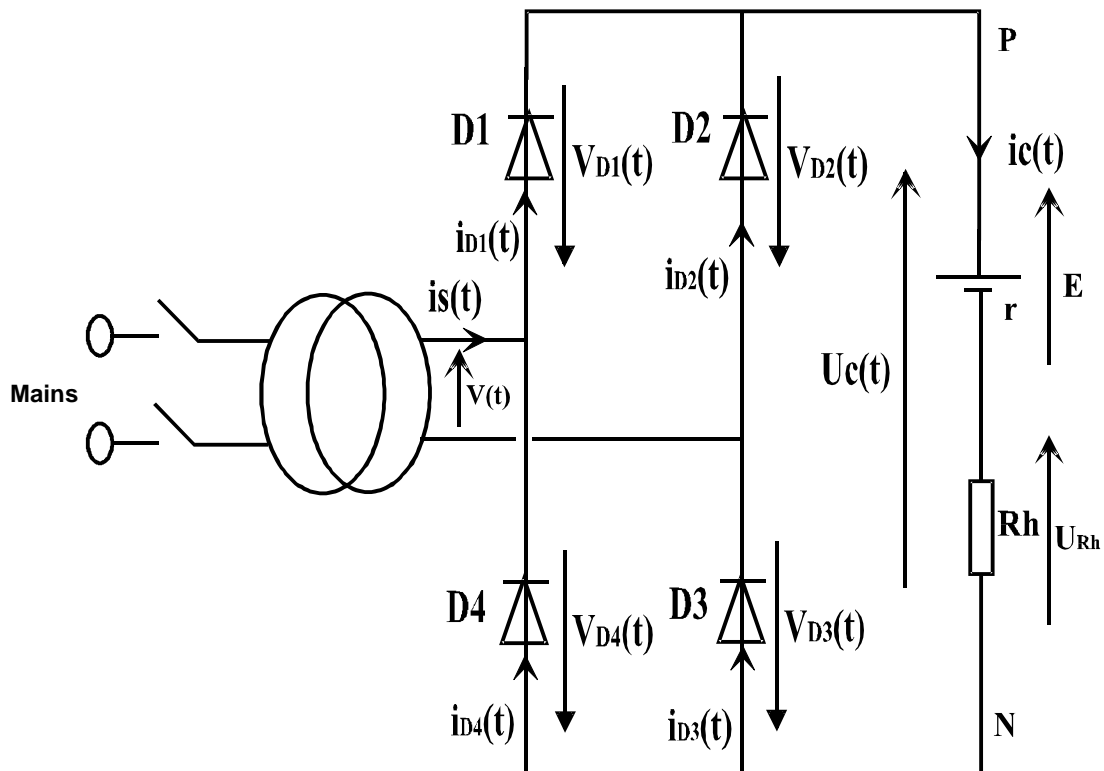

B Action of the circuit

➤ Tensions waveforms

1 Sketch $V(t)$ and $U_C(t)$ separately or use a differential probe in order to visualize both signals.

Sketch $U_{Rh}(t)$ and E .

2 Visualize $V_{D1}(t)$ and $V_{D4}(t)$.

3 Visualize $V_{D2}(t)$ and $V_{D3}(t)$.

➤ Currents waveforms

1 After $U_{Rh}(t)$ graph, sketch $i_C(t)$.

2 With the current probe visualize $i_{D1}(t)$, $i_{D2}(t)$, $i_{D3}(t)$ and $i_{D4}(t)$.

3 Visualize the transformer secondary output current $i_S(t)$.

C Action analysis

➤ First half of cycle

1 Specify the considered interval and the sign of $V(t)$.

2 Give any instantaneous relation between $U_C(t)$, $i_C(t)$, R_h and E .

3 When $V(t) \leq E$, show that no current passes through the load and verify that $U_C(t) = E$.

Verify that all diodes are in off state.

4 When $V(t) > E$, state the conducting diodes.

Give their repetitive peak inverse voltage

Measure the on state interval of the conducting diodes, $\Delta\tau$.

Derive the following expression :

$$i_C(t) = \frac{V\sqrt{2}}{R_h} \sin \omega t - \frac{E}{R_h}$$

From this equation, specify $\Delta\tau$.

Verify that $\Delta\tau$ is centred on $T/4$.

➤ **Second half of cycle**

1 Specify the coincided interval and the sign of $V(t)$.

2 Same survey as before.

Derive the following expression :

$$i_c(t) = -\frac{V\sqrt{2}}{R_h} \sin \omega t - \frac{E}{R_h}$$

➤ **Full cycle**

1 Verify that $i_c(t)$ is a unidirectional current and the conduction is not continuous.

2 Deal with $i_s(t)$ (waveform).

What is the action of the bridge towards the battery ?

3 Note the characteristics of the battery.

Calculate the time τ_{Ch} needed to load the battery under \bar{I}_c current condition.

How can we regulate the load current ?

D remarkable values

➤ **Average currents**

Assuming :

$$\bar{I}_c = \frac{2\sqrt{2}V}{R_h} \left(\frac{1}{2} \cos \omega t_1 - \frac{\Delta\tau}{T} \sin \omega t_1 \right)$$

Where $T = 20 \text{ ms}$

Measure \bar{I}_C and compare it with the previous equation.

Show that $\bar{I}_{D=} = \frac{\bar{I}_C}{2}$

Measure I_C and find the alternative part $I_{Ca} = \sqrt{I_C^2 - \bar{I}_C^2}$ and find the wave ratio $\Omega = \frac{I_{Ca}}{\bar{I}_C}$

➤ **Average voltage across the load**

Measure \bar{U}_C and compare with $\bar{U}_C = E + R \bar{I}_C$

➤ **Power**

Measure the incoming power P_T at the load.

Calculate $P_U = E \bar{I}_C$

Deduce losses : $P_J = P_T - P_U$

Determine the efficiency $\eta = \frac{P_u}{P_T}$

Measure the apparent power at the output of the transformer and compare with $S = V I_S = V I_C$

Calculate the power factor $k = \frac{P_T}{S}$

PANEL B EXP N°4 ACTIVE INDUCTANCE LOAD

A Circuit

LOAD : From the previous experiment, let add in series with the load a variable inductance.

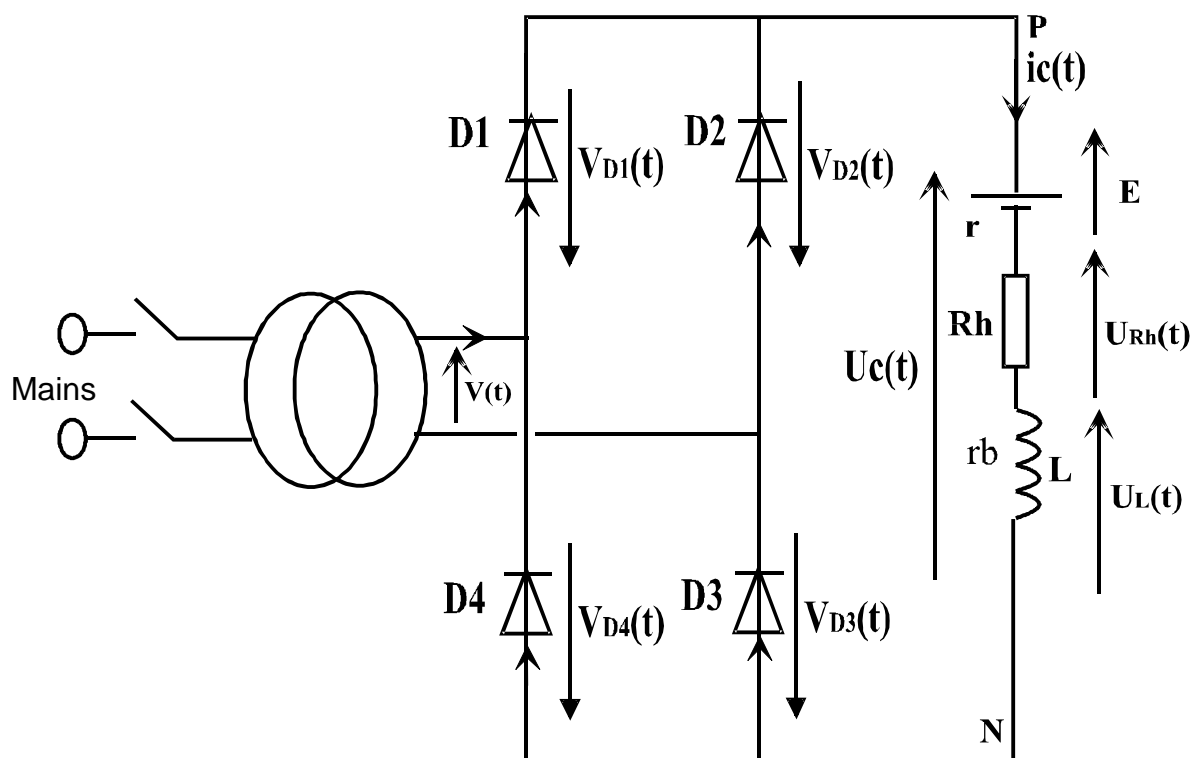

➤ **Continuous conduction**

1 State the changes about $i_{D1}(t)$, $i_{D2}(t)$, $i_{D3}(t)$, $i_{D4}(t)$ and the voltage across the load.

2 Sketch $U_C(t)$ and $i_C(t)$.

3 Fill the following table.

L (H)	0.13	0.4	0.6	0.8	1	1.2
E						
\bar{U}_{Rh}						
\bar{U}_L						
\bar{U}_C						
\bar{I}_C						

Verify : $\bar{U}_C = \bar{U}_L + \bar{U}_{Rh} + E$

Why $\bar{U}_L \neq 0$?

Measure $R_T = R_h + r + r_b$

where R_h is the load resistance,

r , the battery internal resistor, $r = \frac{E_{Ch} - E_0}{\bar{I}_C}$

r_b , inductance internal resistor, $r_b = \frac{\bar{U}_L}{\bar{I}_C}$

➤ **Disrupted conduction**

Replace the previous inductance by a 20 mH inductance or dismantle transformer coil.

What about $U_C(t)$ and $i_C(t)$?

PANEL B EXP N°5 DC MOTOR

A Circuit

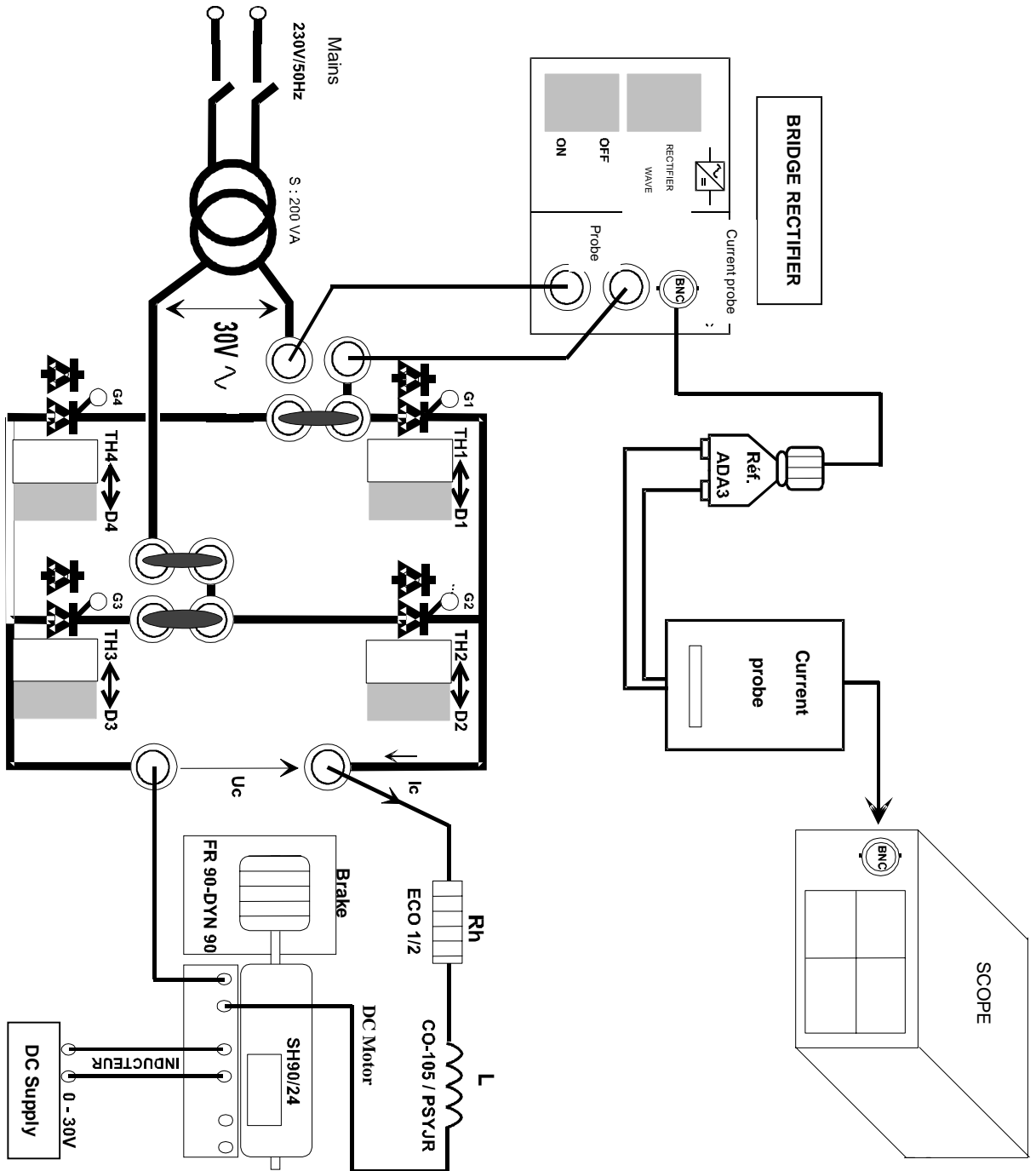

LOAD : In a first time a 20 mH inductance is used (ref. CO-105) and in a second time a variable inductance is used. Both are placed in series with a dc motor (ref. SH 90/24).

4 Supply the inductor of the motor then its armature

Visualize and deal with $U_c(t)$ waveform. What about the different steps?

Notice the motor speed.

5 Visualize $i_c(t)$ through the motor and explain why the conduction is disrupted.

What about the different peaks?

6 Connect a 20 mH smoothing inductance.

What about $u_c(t)$ and $i_c(t)$ waveforms?

What about the conduction mode?

Visualize and deal with $U_c(t)$ and $i_c(t)$.

7 Replace the previous inductance by a variable inductance (ref. PSYJR).

Specify the conduction mode and deal with $U_c(t)$ and $I_C(t)$.

Why does motor speed decrease?

➤ We chose $L = 0.1 \text{ H}$

Visualize and deal with $U_c(t)$ and $I_C(t)$.

Measure and deal with \bar{U}_C .

Measure and deal with \bar{I}_C . Calculate the internal resistor of the variable inductance.

Measure \bar{U}_M and verify $\bar{U}_C = \bar{U}_M + \bar{U}_L$.

Compare \bar{U}_C with its theoretical expression.

Can the speed motor be modified?.

After the previous results, give a method to determine the armature resistor and the speed factor (k).

PRACTICAL WORKS: CONTROLLED RECTIFICATION

The aim of these practical works is to introduce the SCR. This component is a controlled switch. When its gate is correctly biased, a SCR is in conducting state.

It remains in this state as long as the current through it becomes nil or a reverse voltage is applied to it.

With a SCR we can obtain a constant tuneable voltage across the load.

This is very useful in servings applications, when motor speed must be adjusted.

An other application is the *wave generator* which action is to get back power from the load during braking intervals. (subway).

I HALF WAVE AND FULL WAVE CENTER TAPPED RECTIFICATION

➤ Half wave rectification

- Connection straps separately used

Half wave rectification can be studied with either C_1 connection strap (fig 1.a) or C_2 connection strap (fig 1.b).

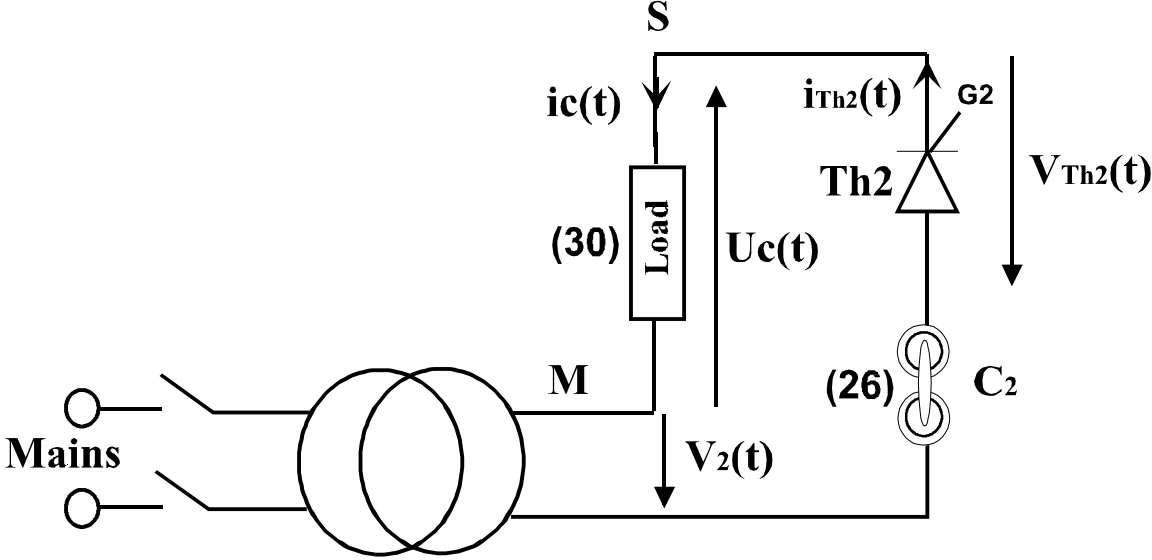

Fig 1.a

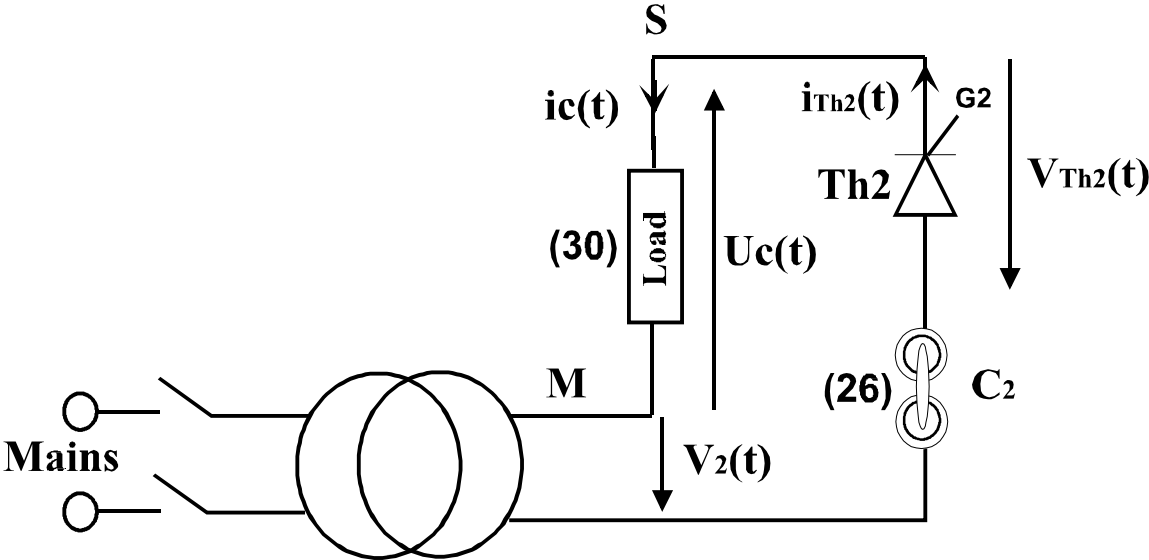

Fig 1.b

➤ Full wave rectification (fig 1.c)

- Both connection straps

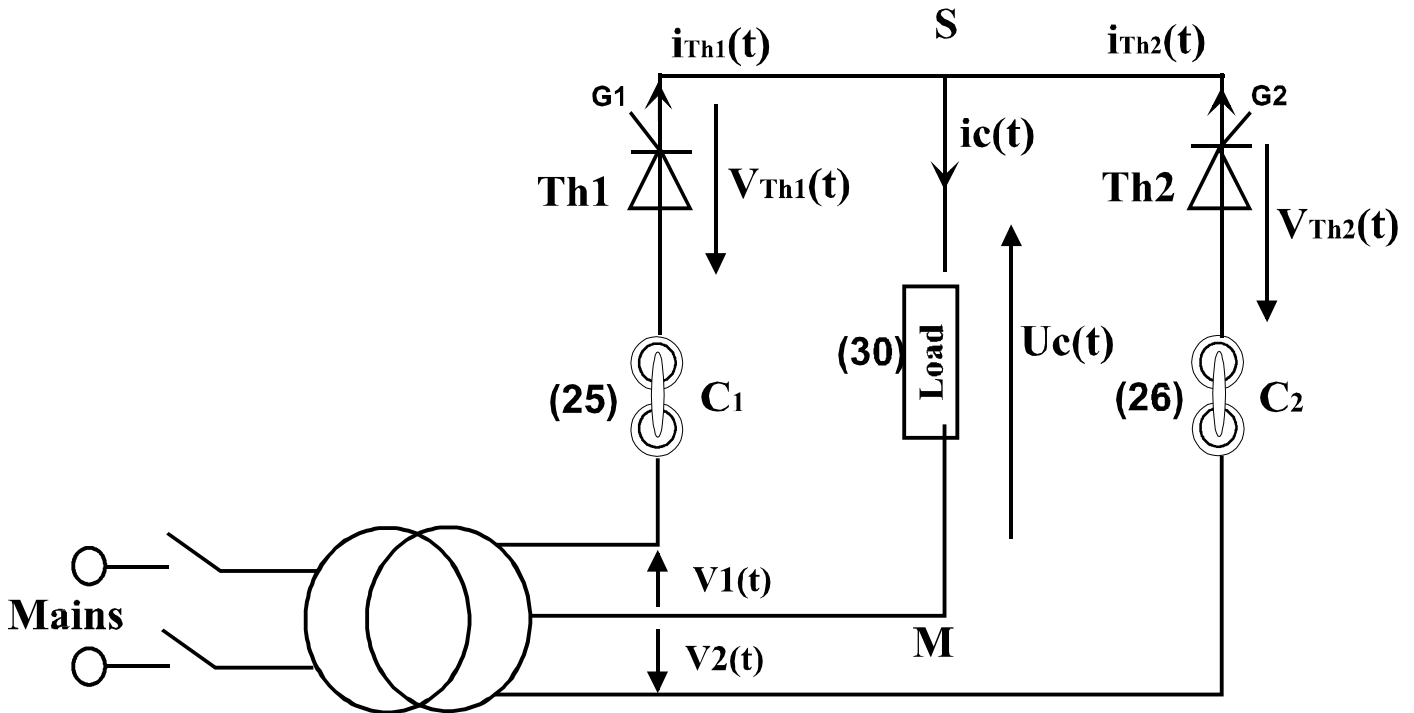

Fig 1.c

Remarks :

- 1) The angle of lag, α , is calculated after the diodes conduction times (natural switching)
- 2) Previous results will be seen again and applied to SCRs. This allows to make an easy comparison between controlled and uncontrolled components.

First result: When cathodes of 2 SCRs are biased each other, the conducting SCR is the one whose anode's potential is superior to the anode's potential of the other SCR. The conducting SCR forces its anode's potential to the cathode of the other SCR.

Second result: When anodes of 2 SCRs are biased each other, the conducting SCR is the one whose cathode's potential is inferior to the cathode's potential of the other SCR. The conducting SCR forces its cathode's potential to the anode of the other SCR.

Third result: The on-state of a SCR involves the other SCR to be in the off state.

PANEL C RESISTIVE LOAD

A SCRs control

1 When $\alpha = 30^\circ$ and $\alpha = 120^\circ$, visualize the gate signal of T_{h1} on channel 1 and the gate signal of T_{h2} on channel 2 (respectively named G_1 and G_2 , BNC socket).

Compare the scope display with the bench LCD display.

2 Give the conducting dates of T_{h1} and T_{h2} when α changes from 0° to 180° .

What about the pulses chain ?

What is the main advantage of such control ?

Measure the frequency of these pulses.

B Circuits

LOAD : 10 Ω/5.7 A (320 W) or 15 Ω/4.5 A (320 W) rheostat, Rh

➤ **Half wave controlled rectification**

▪ **C_1 connection strap only**

1 Visualize $V_1(t)$ on channel 1 and $U_C(t)$ on channel 2. What about $U_C(t)$ towards α variations. ?

When $\alpha = 60^\circ$, sketch $V_1(t)$, $U_C(t)$ and G_1 .

2 Keep these settings and use « INV » and « ADD » functions in order to visualize $V_{TH1}(t)$.

Verify the following expression :

$$V_1(t) = U_C(t) + V_{TH1}(t)$$

3 Commute (11) while α is tuned.

Compare U_C with U_c in non controlled rectification.

Explain why a SCR is often called « controlled diode ».

4 Explain briefly the action of the circuit and notice when T_{h1} is in the on state.

- **Remove C_1 and place C_2**

5 Visualize $V_2(t)$ on channel 1 and $U_C(t)$ on channel 2. What about $U_C(t)$ towards α variations. ?

When $\alpha = 60^\circ$, sketch $V_2(t)$, $U_C(t)$ and G_2 .

6 Keep these settings and use « INV » and « ADD » functions in order to visualize $V_{TH2}(t)$.

Verify the following expression :

$$V_2(t) = U_C(t) + V_{TH2}(t)$$

7 Compare this circuit with the previous one.

8 Explain briefly the action of the circuit and notice when T_{h2} is in the on state.

➤ **Full wave rectification**

- **C_1 and C_2 used ($\alpha = 60^\circ$)**

1 Visualize $U_C(t)$ after removing and placing again successively C_1 and C_2 .

2 Commute (11) and (12) and notice uncontrolled rectification.

3 Explain the action of this circuit.

4 What about $\alpha = 0^\circ$ and $\alpha = 180^\circ$?

5 Show that $i_C(t)$ is unidirectional current (from S to M).

C Remarkable values

1 Fill the following table :

α	0	30°	60°	90°	120°	150°	180°
\bar{U}_c practical							
\bar{U}_c theoretical							
\bar{I}_c practical							
\bar{I}_c theoretical							

2 Plot $\bar{U}_c = f(\alpha)$

Point out the uncontrolled rectification.

3 Find these practical results for half wave rectification.

Compare these results with full wave rectification results.

II FULL SCRs BRIDGE RECTIFIER

The four previous diodes are replaced by controlled components.

Commutate (11), (12), (13) and (14) into SCRs position.

PANEL D EXP N°1 ACTIVE LOAD

A Circuit

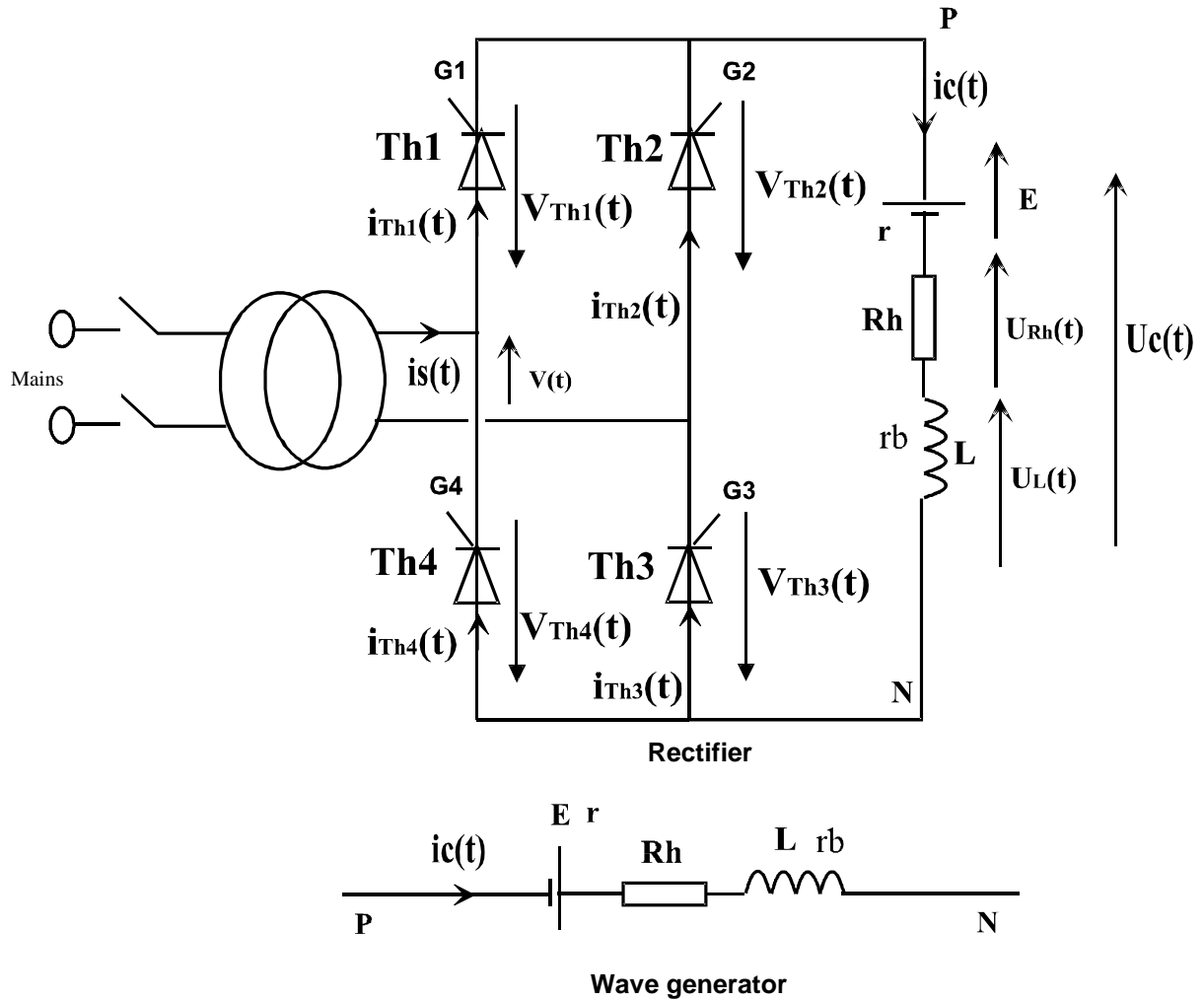

B Rectifier mode

LOAD : 10 Ω /5.7 A (320 W) or 15 Ω / 4.5 A (320 W) rheostat, Rh
6 V battery (or 12 V), variable inductance, $L_{\max} = 1.2$ H

- **Commute (4) into rectifier mode**

A SCRs control

1 When $\alpha = 30^\circ$, visualize G_1 on channel 1 and G_2 on channel 2.

2 Guess and sketch G_3 and G_4 .

➤ Continuous conduction

1 Place meters for U_c , I_c , \bar{U}_c , \bar{I}_c and P.

2 Verify that the conduction is continuous.

The green indicator is on

Tune α up to continuous conduction limit.

Call α_{\max} this value.

3 Sketch $V(t)$, $U_c(t)$, $i_c(t)$ and $i_s(t)$ when $\alpha = 30^\circ$.

4 Fill the following table :

α							α_L
\bar{U}_c practical							
\bar{U}_c theoretical							
\bar{I}_c practical							
\bar{I}_c theoretical							
\bar{P} practical							
\bar{P} theoretical							

5 Plot $\bar{U}_c = f(\alpha)$, $\bar{I}_c = f(\alpha)$, $\bar{P} = f(\alpha)$

6 Verify after the table : $\bar{U}_c = \bar{U}_L + \bar{U}_{Rh} + E$

7 Visualize $U_L(t)$ in ac and dc mode.

What the meaning of \bar{U}_L ? Determine the inductance internal resistor.

8 Measure and calculate R_T . $R_T = R_h + r + r_b$

where R_h is the 10 Ω load resistor,

r , the battery internal resistor $r = \frac{E_{CH} - E_0}{\bar{I}_c}$.

9 Connect a free wheeling diode D_r in parallel with the load. What about $U_c(t)$, and \bar{I}_c ?

10 Power

The transformer supplies P_s .

$$P_s = P_{\text{load}} = \bar{U}_c \bar{I}_c \quad \text{where } \bar{U}_c = \frac{\hat{V}}{\pi} \bar{I}_c \cos \alpha$$

The apparent power is given by :

$$S = \frac{\hat{V}}{\sqrt{2}} \bar{I}_c$$

When $\alpha = 30^\circ$ and $\alpha = 60^\circ$, measure P_s , S and calculate the power factor k .

Compare k with $0.9 \cos \alpha$.

How can we consider α in time scale ?

➤ **Disrupted conduction**

1 Chose $\alpha = 30^\circ$ and remove the inductance

Visualize $U_c(t)$ and $i_c(t)$.

What is the interest of this circuit if the load is a battery ?

2 Replace the previous inductance by a 20 mH one or dismantle transformer coils.

What about $U_c(t)$ and $i_c(t)$. Deal with the flats on $U_c(t)$ waveform.

3 Tune R_h while the disrupted conduction is reached (limit).

C Wave generator mode

LOAD : 10 Ω / 5.7 A (320 W) or 15 Ω / 4.5 A (320 W) rheostat, Rh
24 V battery (or 12 V), variable inductance, Lmax = 1.2 H

▪ Commute (4) into wave generator mode

1 Warning : connect properly the terminals of the battery.

➤ Continuous conduction

2 Verify that continuous conduction is reached.

The red indicator is on.

3 Sketch $V(t)$, $U_C(t)$, $i_C(t)$ and $i_S(t)$ when $\alpha = 120^\circ$.

4 Fill the following table :

α	100°	105°	110°	115°	120°	125°	130°	α_L
\bar{U}_C practical								
\bar{U}_C theoretical								
\bar{I}_C practical								
\bar{I}_C theoretical								
\bar{P} practical								
\bar{P} theoretical								

5 Plot $\bar{U}_C = f(\alpha)$, $\bar{I}_C = f(\alpha)$, $\bar{P} = f(\alpha)$

6 Verify after the table : $\bar{U}_C = \bar{U}_L + \bar{U}_{Rh} + E$

7 Why does $U_C(t)$ sign and not $i_C(t)$ makes P to be negative ?

Which value for α makes the power from load to source to be maximal ?

When $\alpha = 120^\circ$, how can we tune P ?

Tune the circuit in order to reach $P = 5W$

8 What about power sign according to rectifier or wave generator mode ?

What about the source voltage frequency and the voltage frequency across the load ?

➤ **Disrupted conduction**

1 Chose $\alpha = 30^\circ$ and remove the inductance.

Visualize $U_C(t)$ and $i_C(t)$.

PANEL D EXP N°2 DC MOTOR

LOAD : 0.1 H to 1.4 H variable inductance (ref. PSYJR) or a 20 mH inductance (ref. CO-105) in series with a dc-motor (ref. SH 90/24)

1 Supply first the inductor of the motor then its armature.

2 Visualize $U_C(t)$ across the motor terminals.

How does the motor behave when α is increasing from zero ?

3 Visualize $i_C(t)$ and tell why the conduction is disrupted.

4 We place a variable inductance. Tell about the conduction mode and deal with the action of this smoothing inductance.

Why does the speed decrease ?

▪ **L = 0.1 H, continuous conduction**

Visualize $U_C(t)$ and $i_C(t)$

Compare these waveforms with the ones obtained in *Panel D exp. n°1*.

Verify $\bar{U}_C = \bar{U}_M + \bar{U}_L$

What do you notice while the inductance is removed ?

5 Place the inductance again and brake gently the motor up to disrupted mode is reached.

Replace the previous inductance by lower ones. Visualize $U_C(t)$ and $i_C(t)$ What about the conduction mode ?

Act on α , L or the brake and see how conduction is modified.

6 Fill the following table (continuous conduction, L = 0.1 H).

α			α_{\max}
\bar{U}_C practical			
N speed			

7 After the table, verify that : $\bar{U}_C = \bar{U}_M + \bar{U}_L$

8 Plot $\bar{U}_C = f(\alpha)$ and $N = f(\alpha)$

III SCRs/DIODES BRIDGE RECTIFIER

This type of circuit can not be used for wave generator applications. It offers the best power factor and its control is more flexible than a full SCRs bridge.

Each arm of the bridge contains one SCR and one diode in series.

Two arrangements are used :

- Symmetrical bridge fig 1
- Non symmetrical bridge fig 2

PANEL D EXP N°3 ACTIVE INDUCTANCE LOAD

COMPARISON BETWEEN SCRs BRIDGE AND SCRs/DIODES BRIDGE

LOAD : 10Ω/5.7 A (320 W) or 15 Ω/4.5 A (320 W) rheostat, Rh ; 6V battery (or 12 V) ; 1.2 H max variable inductance

- SYMMETRICAL BRIDGE

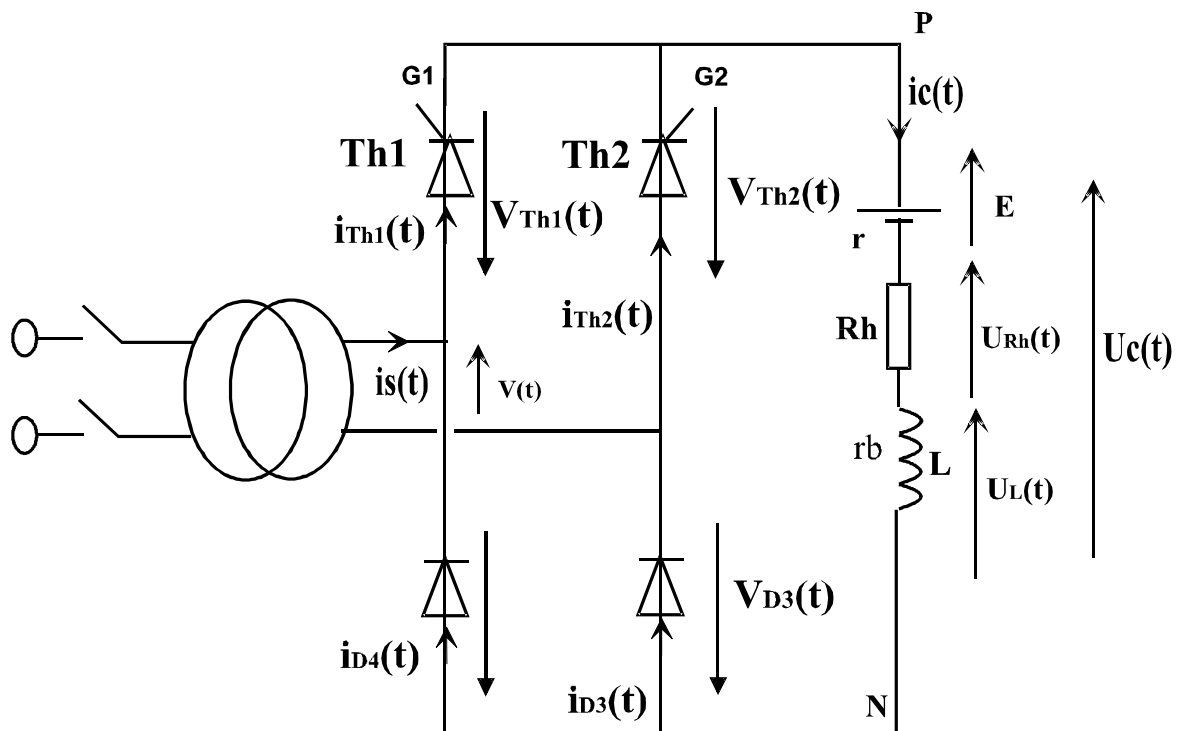

Fig 1.

- **NON SYMMETRICAL BRIDGE**

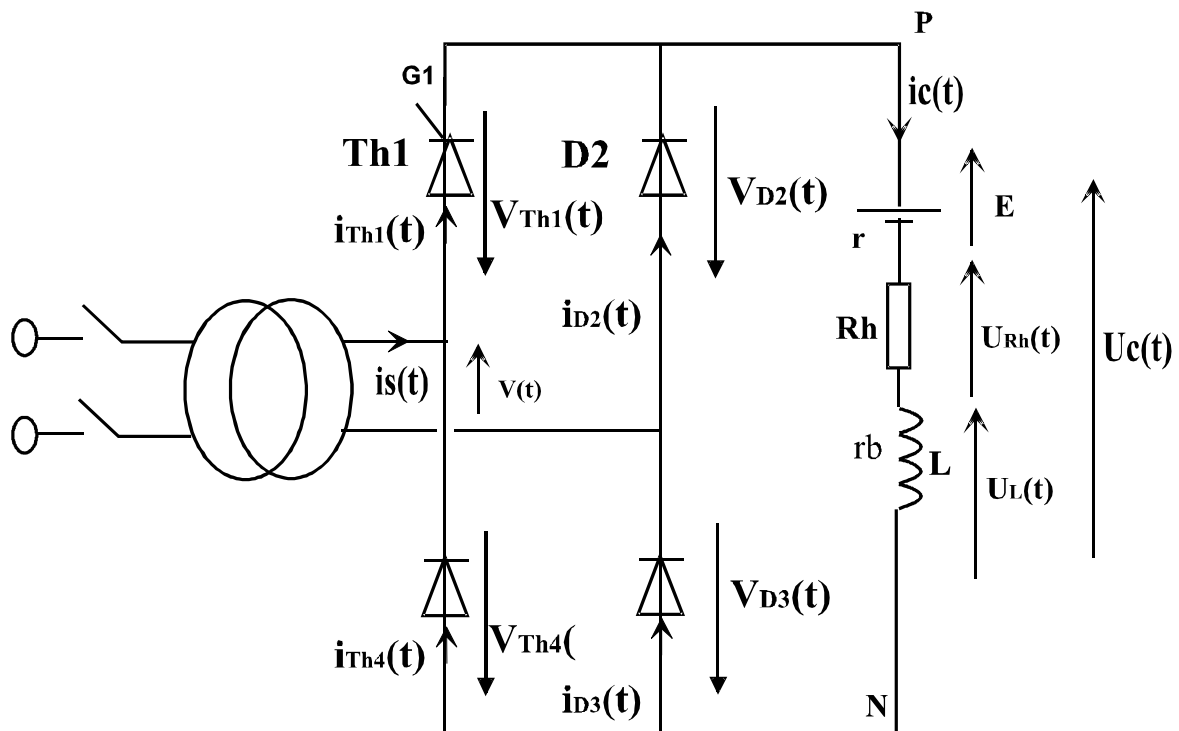

Fig 2 .

- **Commute (4) in rectifier mode**

Place meters for U_c , I_C , \bar{U}_C , \bar{I}_C and P .

A Preliminary survey : induced load

1 For $0^\circ \leq \alpha \leq 180^\circ$, change from symmetrical arrangement to non symmetrical.

In both cases :

Visualize and compare $U_c(t)$ and $i_c(t)$.

Visualize and explain the currents waveforms through each rectifier component.

Explain briefly the action of each arrangement.

2 Chose $\alpha = 60^\circ$ in symmetrical arrangement.

Using a differential probe, visualize and sketch $V(t)$, $U_C(t)$, $i_{Th1}(t)$, $i_{Th2}(t)$, $i_{Th3}(t)$, $i_{Th4}(t)$, $i_{D1}(t)$, $i_{D2}(t)$, $i_S(t)$ and $i_C(t)$.

Explain briefly the action of this circuit. State the name of the conducting components below the gate signals chronograms.

3 Commute (11), (12), (13) and (14) in order to obtain a SCRs bridge.

Compare these waveforms with the previous ones.

Tuning α , compare \bar{U}_C and \bar{I}_C while passing from SCRs bridge to SCRs/diodes bridge.

B Active inductance load

We add a 6V or 12 V accumulators cell.

1 Same questions as before.

Make a comparison with the previous results and show that disrupted conduction is reached for a remarkable value of α called α_L .

2 Place the load in order to show the reversing function of a SCRs bridge.

3 Fill the following table (SCRs/diodes bridge).

α							α_L
\bar{U}_C practical							
\bar{U}_C theoretical							
\bar{I}_C practical							
\bar{I}_C theoretical							
\bar{P} practical							
\bar{P} theoretical							

Plot $\bar{U}_C = f(\alpha)$, $\bar{I}_C = f(\alpha)$, $\bar{P} = f(\alpha)$

Verify after the table : $\bar{U}_C = \bar{U}_L + \bar{U}_{Rh} + E$

Visualize $U_L(t)$ in ac and dc mode.

What about \bar{U}_L ? Determine the inductance internal resistor r_b .

Measure and calculate R_T . $R_T = R_h + r + r_b$

where R_h is the 10Ω load resistor,

r , the battery internal resistor $r = \frac{E_{CH} - E_0}{\bar{I}_C}$.

Express \bar{I}_C as a function of V , E , α , R_h and r . So find α_L .

What about \bar{U}_C and α if we want $\bar{I}_C = 0.7A$?

Connect a free wheeling diode D_r in parallel with the load.

What about $U_C(t)$, and $i_S(t)$?

What about the conduction time interval of each rectifier component ?

What is the action of the free wheeling diode ?

Power ; we assume the bridge is lossless.

The transformer supplies P_s .

$$P_s = P_{load} = \bar{U}_C \bar{I}_C \quad \text{where } \bar{U}_C = \frac{2\hat{V}}{\pi} \bar{I}_C \cos\alpha$$

The apparent power is given by :

$$S = \frac{\hat{V}}{\sqrt{2}} \bar{I}_s$$

Chose $\alpha = 30^\circ$ (continuous conduction)

- **SCRs bridge rectifier**

Measure \hat{V} , \bar{U}_C and \bar{I}_C .

Measure or calculate PS.

Measure or calculate S ($I_S = \bar{I}_C$)

Calculate k (compare it with $0.9 \cos. 30^\circ$)

- **SCRs/diodes bridge rectifier**

Tune α for $\bar{U}_C = \bar{U}_{SCRs}$

Show that $P_{SCRs/diodes} = P_{SCRs}$

Work out I_S from an area analysis ($i_S(t)$ on scope). So find S.

- **Compare both power factors.**

PANEL D EXP N°4 DC-MOTOR

Same questions as *Panel D exp. n°2* and make a comparison with *Panel D exp. n°3*.

